

FX20 series Modular I/O System CC-Link IE Field Basic User Manual



CC-Link **IE** **F**ield
Basic

Content

1. Product introduction.....	3
2. Version change record	3
3. About obtaining manuals.....	3
4. Warranty statement	3
5. Precautions	3
5.1. Safety statement.....	3
5.2. Definition of safety level	4
5.3. Safety and tips.....	4
6. FX20 Product Introduction.....	7
6.1. Appearance and function of CC-Link IE Field Basic bus adapter	7
6.2. FX20 CC-Link IE Field Basic adapter technical data.....	8
6.3. FX20 CC-Link IE Field Basic adapter profile drawing.....	9
6.4. Introduction to the appearance of I/O modules	9
6.4.1. 8-channel digital input/output module	9
6.4.2. 16-channel digital input output module.....	18
6.4.3. 32-channel digital input output module.....	23
6.4.4. 4-channel analog input/output module	28
6.4.5. 8-channel analog input output modules	32
6.4.6. 4-channel temperature measurement modules.....	37
6.4.7. Auxiliary power module.....	40
7. Mechanical installation and disassembly	43
7.1. Installation location and minimum installation distance.....	43
7.1. FX20 adapter installation	43
7.2. FX20 submodules installation	43
7.3. Modules disassembly.....	44
8. Electrical installation and wiring.....	46
8.1. Cable specification	46
8.1.1. Communication cable	46
8.1.2. Power and signal cables	46
8.2. Modules wiring diagram	48
8.2.1. FX20 system power supply diagram	48
8.2.2. Bus adapters wiring diagram	49
8.2.4. 8-channel DO PNP module wiring diagram and I/O mapping	50
8.2.5. 8-channel DO NPN module wiring diagram and I/O mapping.....	50
8.2.6. 4-channel SSR (AC) output module wiring diagram I/O mapping	51
8.2.7. 8-channel relay output module wiring diagram and I/O mapping.....	51
8.2.8. 16-channel DI module wiring diagram and I/O mapping	52
8.2.9. 16-channel DO PNP module wiring diagram and I/O mapping	52
8.2.10. 16-channel DO NPN module wiring diagram and I/O mapping.....	53
8.2.11. 32-channel DI module wiring diagram and I/O mapping	54

8.2.12.	32-channel DO PNP module wiring diagram and I/O mapping	55
8.2.13.	32-channel DO NPN module wiring diagram and I/O mapping.....	56
8.2.14.	4-channel AI module wiring diagram and I/O mapping.....	57
8.2.15.	4-channel AO module wiring diagram and I/O mapping.....	57
8.2.16.	8-channel AI module wiring diagram and I/O mapping.....	58
8.2.17.	8-channel AO module wiring diagram and I/O mapping.....	59
8.2.18.	4-channel RTD module wiring diagram and I/O mapping	60
8.2.19.	4-channel TC module wiring diagram and I/O mapping.....	60
8.2.20.	Auxiliary power module wiring diagram.....	61
9.	Configuration and test	62
9.1.	FX20 I/O Mapping in CC-Link IE Field Basic.....	62
9.2.	CC-Link IE Field Basic profile	62
9.3.	FX20 configuration and test in Mitsubishi GX Works3.....	63
9.4.	FX20 parameters configuration in web server	72
9.5.	Representation of analog module values	79
9.3.1.	Analog value input and output range of bipolar current.....	79
9.3.2.	Analog value input and output range of bipolar voltage.....	79
9.3.3.	Analog value input and output range of unipolar current.....	80
9.3.4.	Analog value input and output range of unipolar voltage.....	80
9.3.5.	Analog value measurement range of PT x00 standard thermal resistance	81
9.3.6.	Representation of simulated values within the measurement range of thermocouples.....	81
10.	Fault diagnosis	82

1. Product introduction

The FX20 series modular I/O system is a new generation IP20 expandable I/O product launched by Elco. It's composed of bus adapters, I/O modules and functional modules, with the min. module width of only 15 mm, which is thin and compact, greatly saving space inside the control cabinet. The wiring terminal is designed with two separate sections, which facilitates module replacement and maintenance. Keeping the fresh family color scheme, it provides practical tool-free spring terminals for fast and convenient wiring. The terminal buttons are identified by color, and different colors represent different functions, improving the efficiency of wiring and checking to the most.

FX20 adopts high-speed backplane bus technology, with high communication bandwidth and fast response speed, which can meet the application of high-speed production takt. By simply replacing the bus coupler, different automation bus systems can be connected. Currently, it is mainly compatible with mainstream Ethernet bus protocols such as EtherCAT, PROFINET, EtherNet/IP, CC-Link IE Field Basic, and can expand up to 32 functional modules.

FX20 has a wide range of functional modules with powerful functions, including digital input and output, relay output, analog input and output, temperature measurement, high-speed counting, IO-Link master station, communication bridge, etc. It can meet the needs of various automation systems and is widely used in industries such as automobile manufacturing, parts processing, 3C electronics, lithium battery equipment, photovoltaic, logistics, printing and packaging.

This manual mainly introduces the mechanical installation, electrical installation, and module configuration examples of FX20 products.

2. Version change record

Revision date	Version	Content changed
2025-07	V1.0	1st version
2025-12	V2.0	Update fonts and layouts

3. About obtaining manuals

This manual is not shipped with the product. You can obtain its PDF file through the following methods:

- Log in to Elco's official website (www.elcoautomation.com), search for keywords, and download.
- Use WeChat to search and subscribe the official account of "Elco Automation" to obtain the product manual.
- Contact Elco sales engineers in your area to obtain the latest manual materials.

4. Warranty statement

Under normal use, if the product malfunctions or is damaged, Elco will be responsible for an 18 months warranty (from and subject to the delivery date; executed according to the agreement, if there is a contract). When it's over 18 months, maintenance fees will be charged.

- Within 18 months, repair fees will be charged for product damaged by the following circumstances.
- Failure to operate according to the manual
- Fires, floods, and abnormal voltage
- Used for abnormal functions
- Beyond the application scope
- Force majeure (natural disasters, earthquakes, lightning strikes).

The service fees shall be calculated according to Elco's unified standards. Subject to the contract, if there is.

5. Precautions

5.1. Safety statement

- 1) Please read and follow these precautions before installing, operating, and maintaining the product.

- 2) To ensure personal and equipment safety, please follow all precautions indicated on the product and in the manual when installing, operating, and maintaining the product.
- 3) The 'caution', 'warning' and 'danger items in the manual do not represent all precautions that should be followed, but only serve as supplements to all safety precautions.
- 4) This product should be used in an environment that meets the design specifications, otherwise it may cause malfunctions. Functional abnormalities or component damage caused by non-compliance with relevant regulations are not within the scope of product quality assurance.
- 5) Elco will not bear any legal responsibility for personal safety accidents, property losses, etc. caused by mishandling of products.

5.2. Definition of safety level

Caution	If not operated properly, it may result in minor body injury or equipment damage
Warning	If not operated properly, it may result in death or serious bodily injury.
Danger	If not operated properly, it will result in death or serious bodily injury.

5.3. Safety and tips

	Reminding		Please refer to the relevant manual content before operation
	Risk of electrical shock		Information tips
	General tips		Only authorized electrical personnel can operate
	Earthing		Only authorized mechanical personnel can operate

When designing control systems

Dangerous!

- Please be sure to design a safety circuit to ensure that the control system can still work safely in the event of external power failure or PLC failure;
- When long time overcurrent caused by exceeding rated load current or short circuit, the module may smoke or catch fire. So, safety devices such as fuses or circuit breakers need to be installed.

When installing

Warning!

- Only professional maintenance personnel who have been trained on electrical equipment and have sufficient electrical knowledge can install this product.

Dangerous!

- During the operation, all external power supplies used by the system must be disconnected. If the power supply is not fully disconnected, it may cause electric shock, module failure or malfunction.
- Do not use programmable controller in the following conditions: places with dust, oil fumes, conductive dust, corrosive gases, and flammable gas.
- Exposed to high temperatures, condensation, and wind and rain; In situations with vibration and impact. Electric

shock, fire, and mis-operation can also cause product damage and deterioration.

- The programmable controller is an Open type device, please install it in a control cabinet with a lock (the IP rating of the control cabinet housing > IP20). Only operators who have been trained on electrical equipment and have sufficient electrical knowledge can open the control cabinet.
- During installation, avoid metal shavings and wire ends falling into the ventilation hole of the controller, which may cause fire, malfunction, and mis-operation.

Caution!

- After installation, ensure that there are no foreign objects on the ventilation surface, otherwise it may cause poor heat dissipation, fire, malfunction, and mis-operation.
- When installing, it needs to be tightly connected to connectors and the module connection hooks need to be securely locked. If the module is installed improperly, it may cause mis-operation, malfunction, and detachment.

When wiring

Dangerous!

- Only professional maintenance personnel who have been trained on electrical equipment and have sufficient electrical knowledge can carry out the wiring of this product;
- During the operation, all external power supplies used by the system must be disconnected. If the power supply is not fully disconnected, it may cause electric shock, module failure or malfunction.

Dangerous!

- Cable terminals should be well insulated to ensure that the insulation distance between cables does not decrease after installation on the terminal block. Otherwise, it may cause electric shock or equipment damage.
- To avoid electric shock, please cut off the power supply before connecting to the power supply of this product;
- The input power specifications of this product can be found in technical specifications. Please provide the power supply strictly in accordance with the data in the technical specifications. If the power supply is not within the required range, it will seriously damage this product. Therefore, please regularly check whether the DC power supply provided by the switching power supply is stable.

During operation and maintenance

Caution!

- Only professional maintenance personnel who have been trained on electrical equipment and have sufficient electrical knowledge can carry out the maintenance.
- Do not touch the terminals when powered on, otherwise it may cause electric shock or malfunction.
- During the operation, all external power supplies used by the system must be disconnected. If the power supply is not fully disconnected, it may cause electric shock or malfunction.
- At locations where operators directly come into contact with mechanical parts, such as loading and unloading mechanical tools, or where machinery operates automatically, careful consideration must be given to the function of on-site manual devices or other backup means. It needs to be independent of programmable controllers and can start or interrupt the automatic operation of the system.
- If the program needs to be modified while the system is running, it is necessary to consider using locks or other protective measures to ensure that only authorized personnel can make necessary modifications.

When Scrapping

Caution!

- Please treat it as industrial waste;
- Scrapped equipment and products need to be disposed of and recycled according to industrial waste treatment standards to avoid environmental pollution.

Please keep the content of this safety precautions properly for future reference, and be sure to hand over this manual to the end user.

6. FX20 Product Introduction

6.1. Appearance and function of CC-Link IE Field Basic bus adapter



Item	Name	Function	Status
1	Rail locking device	Lock FX20 module	Assembling completed: locking position Disassembling module: unlocking position
2	X1	CC-Link IE Field Basic bus input	-
3	X2	CC-Link IE Field Basic bus output	-
4	Module fixing device	Fixing module and rail	Disassembling module: pull out Assembling completed: press down
5	Coupler running indicator		
	PWR	Indicate power supply	Green: normal Off: abnormal
	BF	Indicate bus status	Green: normal Red: configuration error
	SF	Report system error	Green: normal Red: error
	STA	Indicate backplane communication status	Green: normal Red: Backplane communication error
6	Power input terminal 0 V	0 V access	-
7	Power input terminal 24 V+	24 V DC access	-
8	PE	System grounding	-

6.2. FX20 CC-Link IE Field Basic adapter technical data

FX20-GW-CE00

ARTICLE PROPERTIES

PRODUCT TYPE	FX20 series modular I/O system CC-LINK IE Field Basic adapter	PRODUCT GROUP	IP20 modular I/O system
DESCRIPTION	Gateway module for CC-LINK IE FB, 2 x RJ45, max. 32 cascable modules, 24 V DC, IP20, DIN rail installation, overcurrent / reverse polarity / surge protection	PU	1 pcs
		COUNTRY OF ORIGIN	CN

TECHNICAL DATA

COMMUNICATION PROTOCOL	CC-LINK IE Field Basic	INPUT AND OUTPUT PROCESS MAPPING (MAX.)	288 bytes / 288 bytes
STATION TYPE	Slave station	SUPPLY VOLTAGE (SYSTEM)	24 V DC (± 20 %)
OCCUPIED STATIONS	1	INPUT CURRENT (TYP.) AT NOMINAL LOAD (24 V)	200 mA
TRANSMISSION MEDIUM	Shielded twisted pair S/FTP, F/FTP or SF/FTP, 100 Ω, Cat. 5	BACKPLANE POWER SUPPLY VOLTAGE	5 V DC
TRANSMISSION RATE	100 Mbit/s	BACKPLANE POWER SUPPLY CURRENT (MAX.)	3 A
BUS SEGMENT LENGTH (MAX.)	100 m	ELECTRICAL ISOLATION	500 V (power supply and bus)
BUS NODE ADDRESS	Set by PLC configuration software	POWER PROTECTION	Overcurrent protection, reverse polarity protection, surge protection
WEB SERVER	Supports, the default access address is 192.168.3.10	FAULT DIAGNOSIS METHOD	LED, communication message
MAX. NUMBER OF CASCADABLE MODULES	32		

CONNECTION DATA

WIRE CONNECTION	Plug-in terminal block	STRIPPED LENGTHS	8 ... 10 mm 0.315 ... 0.394 in
CROSS SECTION	0.08 mm ² ... 2.5 mm ² AWG 28 ... 14		

ENVIRONMENTAL REQUIREMENTS

PROTECTION CLASS	IP20	ELECTRICAL FAST TRANSIENT (EFT)	Level A, per IEC 61000-4-4
-------------------------	------	--	----------------------------

MOUNTING TYPE	DIN-35 mm rail	ELECTRO-STATIC DISCHARGE (ESD)	Level A, per IEC 61000-4-2
AMBIENT TEMPERATURE	-5 ... +60 °C	SURGE TEST	Level A, per IEC 61000-4-5
STORAGE TEMPERATURE	-25 ... +70 °C	VIBRATION RESISTANCE	4 g, per IEC 60068-2-6
RELATIVE HUMIDITY	95%, non-condensing	SHOCK RESISTANCE	15 g, per IEC 60068-2-27
OPERATING ALTITUDE	0 ... 2000 m / 0 ... 6562 ft	EU ROHS COMPLIANCE STATUS	Yes
POLLUTION DEGREE	2, per IEC 61131-2	MATERIAL COMPLIANCE	Compliant with REACH

GENERAL DATA

HOUSING MATERIAL	PPE	DIMENSIONS (H X W X D)	110.4 x 57 x 78.5 mm
WEIGHT	230 g	MTTF (25 °C)	111 years
COLOR	Light gray	APPROVALS	CE

6.3. FX20 CC-Link IE Field Basic adapter profile drawing

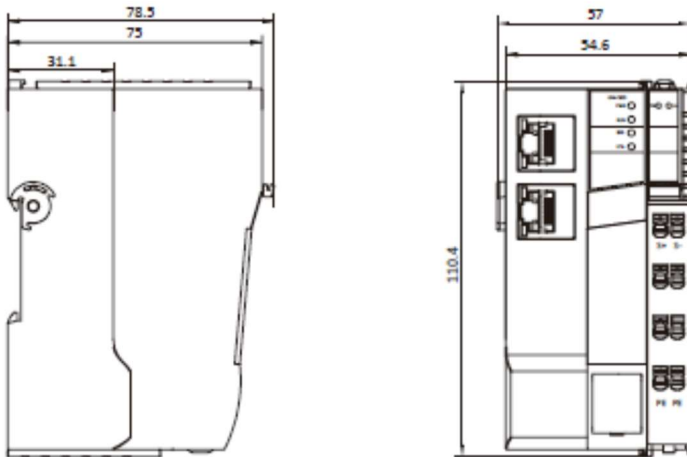

6.4. Introduction to the appearance of I/O modules

6.4.1. 8-channel digital input/output module

6.4.1.1. 8-channel digital input module

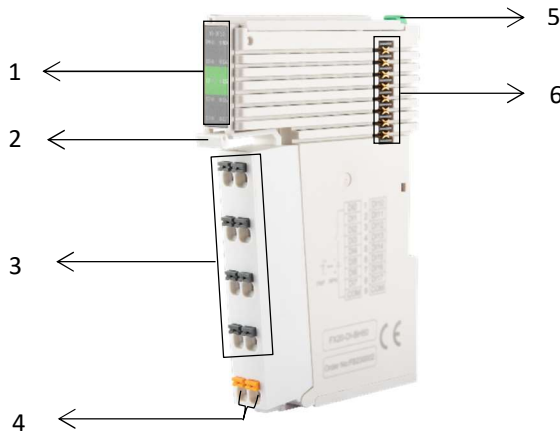

Item	Name	Function	Status
1	Module running indicators		
	PW	Backplane power indicator	Green: normal; Red: I/O power supply abnormal; Off: no backplane power
	MD	Module error indicator	Green: normal Red: Module channel error Green blinking: Connected but not configured; Red and green blinking: Backplane communication abnormal;
	00-07	Input signal indicator	Green: input "1" Off: input "0"
2	Terminal disassembly device	Press the device to separate the terminal block from the module	-
3	IO input terminal 0-7	IO signal wiring	-
4	Common ground terminal	IO signal Common ground terminal	0 V when the input signal is PNP, 24 V+ when the input signal is NPN
5	Module fixing device	Used to fix the module to the standard mounting rail	Pulling up: assembling position; Pressing down: locking position
6	Backplane bus interface	Backplane communication among modules	-

6.4.1.2. 8-channel digital input module technical data

FX20-DI-BF60

ARTICLE PROPERTIES

PRODUCT TYPE	FX20 series modular I/O system digital input modules	PRODUCT GROUP	IP20 modular I/O system
DESCRIPTION	FX20-submodule 8-channel input PNP / NPN, 24 V DC, IP20, DIN rail installation	PU	1 pc
		COUNTRY OF ORIGIN	CN

TECHNICAL DATA

NUMBER OF DIGITAL INPUTS	8	INPUT FILTERING DELAY	0 ms, 1 ms, 3 ms and 10 ms can be configured
INPUT TYPE	PNP / NPN	CURRENT CONSUMPTION (5 V)	60 mA
INPUT SIGNAL '0'	0 ... 5 V DC	PROCESS DATA LENGTH	1 byte
INPUT SIGNAL '1'	18 ... 30 V DC	FAULT DIAGNOSIS METHOD	LED, communication message

INPUT CURRENT PER CHANNEL FOR SIGNAL '1' Typ. 4 mA

CONNECTION DATA

WIRE CONNECTION	Plug-in terminal block	STRIPPED LENGTHS	8 ... 10 mm 0.315 ... 0.394 in
CROSS SECTION	0.08 mm ² ... 2.5 mm ² AWG 28 ... 14		

ENVIRONMENTAL REQUIREMENTS

PROTECTION CLASS	IP20	ELECTRICAL FAST TRANSIENT (EFT)	Level A, per IEC 61000-4-4
MOUNTING TYPE	DIN-35 mm rail	ELECTRO-STATIC DISCHARGE (ESD)	Level A, per IEC 61000-4-2
AMBIENT TEMPERATURE	-5 ... +60 °C	SURGE TEST	Level A, per IEC 61000-4-5
STORAGE TEMPERATURE	-25 ... +70 °C	VIBRATION RESISTANCE	4 g, per IEC 60068-2-6
RELATIVE HUMIDITY	95%, non-condensing	SHOCK RESISTANCE	15 g, per IEC 60068-2-27
OPERATING ALTITUDE	0 ... 2000 m / 0 ... 6562 ft	EU ROHS COMPLIANCE STATUS	Yes
POLLUTION DEGREE	2, per IEC 61131-2	MATERIAL COMPLIANCE	Compliant with REACH

GENERAL DATA

HOUSING MATERIAL	PPE	DIMENSIONS (H X W X D)	110.6 x 15 x 78.4 mm
WEIGHT	63 g	MTTF (25 °C)	155 years
COLOR	Light gray	APPROVALS	CE

6.4.1.3. 8-channel digital output modules

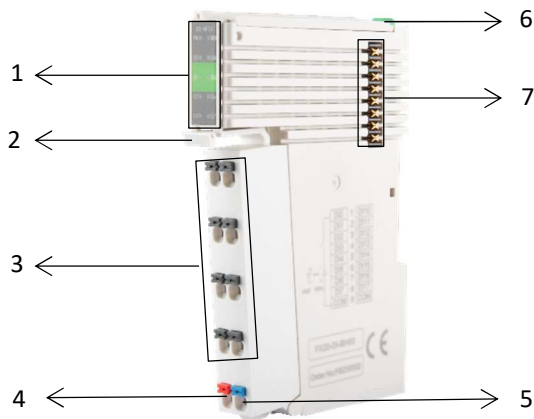

Item	Name	Function	Status
1	Module running indicators		
	PW	Backplane power indicator	Green: normal; Red: I/O power supply abnormal; Off: no backplane power
	MD	Module error indicator	Green: normal Red: Module channel error

			Green blinking: Connected but not configured; Red and green blinking: Backplane communication abnormal;
	00-07	Output signal indicator	Green: output "1" Off: output "0"
2	Terminal disassembly device	Press the device to separate the terminal block from the module	-
3	IO output terminal 0-7	IO signal wiring	-
4	24 V power terminal	24 V+	-
5	24 V power terminal	0 V	-
6	Module fixing device	Used to fix the module to the standard mounting rail	Pulling up: assembling position; Pressing down: locking position.
7	Backplane bus interface	Backplane communication	-

6.4.1.4. 8-channel digital output module technical data

FX20-DO-BF00

ARTICLE PROPERTIES

PRODUCT TYPE	FX20 series modular I/O system digital output modules	PRODUCT GROUP	IP20 modular I/O system
DESCRIPTION	FX20-submodule 8-channel output PNP, 24 V DC, 0.5 A, IP20, DIN rail installation	PU	1 pc
		COUNTRY OF ORIGIN	CN

TECHNICAL DATA

NUMBER OF DIGITAL OUTPUTS	8	SWITCHING FREQUENCY	Max. 1 kHz (Resistive loads) Max. 1 Hz (Inductive loads) Max. 10 Hz (Lamps)
OUTPUT TYPE	PNP	OUTPUT HOLD	Supports, configured by PLC or web server
OUTPUT VOLTAGE	24 V DC	CURRENT CONSUMPTION (5 V)	60 mA
OUTPUT CURRENT	Max. 0.5 A per channel, total 4 A per module	PROCESS DATA LENGTH	1 byte
OUTPUT LOAD TYPES	Resistive loads, inductive loads, lamps	FAULT DIAGNOSIS METHOD	LED, communication message

CONNECTION DATA

WIRE CONNECTION	Plug-in terminal block	STRIPPED LENGTHS	8 ... 10 mm 0.315 ... 0.394 in
CROSS SECTION	0.08 mm ² ... 2.5 mm ² AWG 28 ... 14		

ENVIRONMENTAL REQUIREMENTS

PROTECTION CLASS	IP20	ELECTRICAL FAST TRANSIENT (EFT)	Level A, per IEC 61000-4-4
MOUNTING TYPE	DIN-35 mm rail	ELECTRO-STATIC DISCHARGE (ESD)	Level A, per IEC 61000-4-2
AMBIENT TEMPERATURE	-5 ... +60 °C	SURGE TEST	Level A, per IEC 61000-4-5
STORAGE TEMPERATURE	-25 ... +70 °C	VIBRATION RESISTANCE	4 g, per IEC 60068-2-6
RELATIVE HUMIDITY	95%, non-condensing	SHOCK RESISTANCE	15 g, per IEC 60068-2-27
OPERATING ALTITUDE	0 ... 2000 m / 0 ... 6562 ft	EU ROHS COMPLIANCE STATUS	Yes
POLLUTION DEGREE	2, per IEC 61131-2	MATERIAL COMPLIANCE	Compliant with REACH

GENERAL DATA

HOUSING MATERIAL	PPE	DIMENSIONS (H X W X D)	110.6 x 15 x 78.4 mm
WEIGHT	63 g	MTTF (25 °C)	155 years
COLOR	Light gray	APPROVALS	CE

FX20-DO-BF50

ARTICLE PROPERTIES

PRODUCT TYPE	FX20 series modular I/O system digital output modules	PRODUCT GROUP	IP20 modular I/O system
DESCRIPTION	FX20-submodule 8-channel output NPN, 24 V DC, 0.5 A, IP20, DIN rail installation	PU	1 pc
		COUNTRY OF ORIGIN	CN

TECHNICAL DATA

NUMBER OF DIGITAL OUTPUTS	8	SWITCHING FREQUENCY	Max. 1 kHz (Resistive loads) Max. 1 Hz (Inductive loads) Max. 10 Hz (Lamps)
OUTPUT TYPE	NPN	OUTPUT HOLD	Supports, configured by PLC or web server
OUTPUT VOLTAGE	24 V DC	CURRENT CONSUMPTION (5 V)	60 mA
OUTPUT CURRENT	Max. 0.5 A per channel, total 4 A per module	PROCESS DATA LENGTH	1 byte
OUTPUT LOAD TYPES	Resistive loads, inductive loads, lamps	FAULT DIAGNOSIS METHOD	LED, communication message

CONNECTION DATA

WIRE CONNECTION	Plug-in terminal block	STRIPPED LENGTHS	8 ... 10 mm 0.315 ... 0.394 in
CROSS SECTION	0.08 mm ² ... 2.5 mm ² AWG 28 ... 14		

ENVIRONMENTAL REQUIREMENTS

PROTECTION CLASS	IP20	ELECTRICAL FAST TRANSIENT (EFT)	Level A, per IEC 61000-4-4
MOUNTING TYPE	DIN-35 mm rail	ELECTRO-STATIC DISCHARGE (ESD)	Level A, per IEC 61000-4-2
AMBIENT TEMPERATURE	-5 ... +60 °C	SURGE TEST	Level A, per IEC 61000-4-5
STORAGE TEMPERATURE	-25 ... +70 °C	VIBRATION RESISTANCE	4 g, per IEC 60068-2-6
RELATIVE HUMIDITY	95%, non-condensing	SHOCK RESISTANCE	15 g, per IEC 60068-2-27
OPERATING ALTITUDE	0 ... 2000 m / 0 ... 6562 ft	EU ROHS COMPLIANCE STATUS	Yes
POLLUTION DEGREE	2, per IEC 61131-2	MATERIAL COMPLIANCE	Compliant with REACH

GENERAL DATA

HOUSING MATERIAL	PPE	DIMENSIONS (H X W X D)	110.6 x 15 x 78.4 mm
WEIGHT	63 g	MTTF (25 °C)	155 years
COLOR	Light gray	APPROVALS	CE

6.4.1.5. 8-channel digital input/output module profile drawing

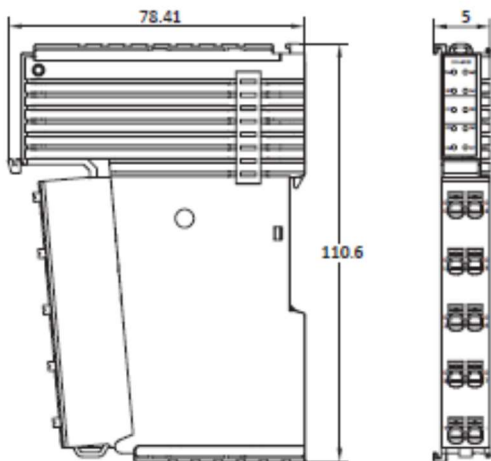

6.4.1.6. 4/8-channel relay output modules

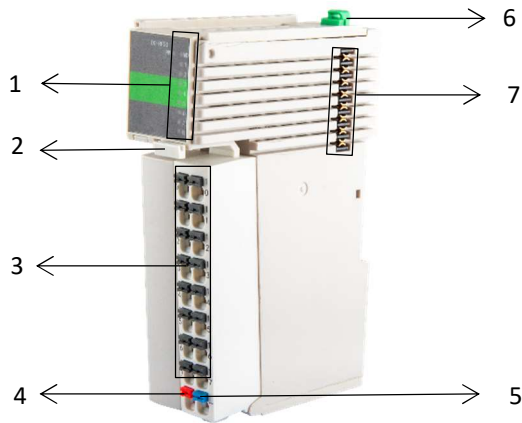

Item	Name	Function	Status
1	Module running indicator		
	PW	Backplane power indicator	Green: normal; Red: I/O power supply abnormal; Off: no backplane power
	MD	Module error indicator	Green: normal Red: Module channel error Green blinking: Connected but not configured; Red and green blinking: Backplane communication abnormal;
	00-07	Output signal indicator	Green: output "1" Off: output "0"
2	Terminal disassembly device	Press the device to separate the terminal block from the module	-
3	IO output terminal 0-7	IO signal wiring	-
4	24 V power terminal	24 V+	-
5	24 V power terminal	0 V	-
6	Module fixing device	Used to fix the module to the standard mounting rail	Pulling up: assembling position; Pressing down: locking position
7	Backplane bus interface	Backplane communication	-

6.4.1.7. 4/8-channel digital relay output modules technical data

FX20-DO-RD00

ARTICLE PROPERTIES

PRODUCT TYPE	FX20 series modular I/O system digital output modules	PRODUCT GROUP	IP20 modular I/O system
DESCRIPTION	FX20-submodule 4-channel output SSR, 230 V AC, IP20, DIN rail installation	PU	1 pc
		COUNTRY OF ORIGIN	CN

TECHNICAL DATA

NUMBER OF DIGITAL OUTPUTS	4	OUTPUT HOLD	Supports, configured by PLC or web server
OUTPUT TYPE	AC solid state relay	RELAY RESPONSE TIME	3 ... 10 ms
CONTACT WORKING VOLTAGE	230 V AC	ELECTRICAL LIFE	20 million times
OUTPUT CURRENT	Max. 0.5 A per channel	CURRENT CONSUMPTION (5 V)	80 mA
OUTPUT LOAD TYPES	Resistive loads, lamps	PROCESS DATA LENGTH	1 byte
SWITCHING FREQUENCY	Max. 0.5 Hz	FAULT DIAGNOSIS METHOD	LED, communication message

CONNECTION DATA

WIRE CONNECTION	Plug-in terminal block	STRIPPED LENGTHS	8 ... 10 mm 0.315 ... 0.394 in
CROSS SECTION	0.08 mm ² ... 2.5 mm ² AWG 28 ... 14		

ENVIRONMENTAL REQUIREMENTS

PROTECTION CLASS	IP20	ELECTRICAL FAST TRANSIENT (EFT)	Level A, per IEC 61000-4-4
MOUNTING TYPE	DIN-35 mm rail	ELECTRO-STATIC DISCHARGE (ESD)	Level A, per IEC 61000-4-2
AMBIENT TEMPERATURE	-5 ... +60 °C	SURGE TEST	Level A, per IEC 61000-4-5
STORAGE TEMPERATURE	-25 ... +70 °C	VIBRATION RESISTANCE	4 g, per IEC 60068-2-6
RELATIVE HUMIDITY	95%, non-condensing	SHOCK RESISTANCE	15 g, per IEC 60068-2-27
OPERATING ALTITUDE	0 ... 2000 m / 0 ... 6562 ft	EU ROHS COMPLIANCE STATUS	Yes
POLLUTION DEGREE	2, per IEC 61131-2	MATERIAL COMPLIANCE	Compliant with REACH

GENERAL DATA

HOUSING MATERIAL	PPE	DIMENSIONS (H X W X D)	110.6 x 28.1 x 78.4 mm
WEIGHT	90 g	MTTF (25 °C)	155 years
COLOR	Light gray	APPROVALS	CE

FX20-DO-RF50

ARTICLE PROPERTIES

PRODUCT TYPE	FX20 series modular I/O system digital output modules	PRODUCT GROUP	IP20 modular I/O system
DESCRIPTION	FX20-submodule 8-channel output mechanical relays, output voltage 250 V AC / 30 V DC, IP20, DIN rail installation	PU	1 pc
		COUNTRY OF ORIGIN	CN

TECHNICAL DATA

NUMBER OF DIGITAL OUTPUTS	8	OUTPUT HOLD	Supports, configured by PLC or web server
OUTPUT TYPE	Mechanical relays	RELAY RESPONSE TIME	About 15 ms
CONTACT WORKING VOLTAGE	250 V AC / 30 V DC	ELECTRICAL LIFE	100,000 times
OUTPUT CURRENT	Max. 2 A per channel	CURRENT CONSUMPTION (5 V)	65 mA
OUTPUT LOAD TYPES	Resistive loads, lamps	PROCESS DATA LENGTH	1 byte
SWITCHING FREQUENCY	Less than 6 times per minute	FAULT DIAGNOSIS METHOD	LED, communication message

CONNECTION DATA

WIRE CONNECTION	Plug-in terminal block	STRIPPED LENGTHS	8 ... 10 mm 0.315 ... 0.394 in
CROSS SECTION	0.08 mm ² ... 2.5 mm ² AWG 28 ... 14		

ENVIRONMENTAL REQUIREMENTS

PROTECTION CLASS	IP20	ELECTRICAL FAST TRANSIENT (EFT)	Level A, per IEC 61000-4-4
MOUNTING TYPE	DIN-35 mm rail	ELECTRO-STATIC DISCHARGE (ESD)	Level A, per IEC 61000-4-2
AMBIENT TEMPERATURE	-5 ... +60 °C	SURGE TEST	Level A, per IEC 61000-4-5
STORAGE TEMPERATURE	-25 ... +70 °C	VIBRATION RESISTANCE	4 g, per IEC 60068-2-6
RELATIVE HUMIDITY	95%, non-condensing	SHOCK RESISTANCE	15 g, per IEC 60068-2-27
OPERATING ALTITUDE	0 ... 2000 m / 0 ... 6562 ft	EU ROHS COMPLIANCE STATUS	Yes
POLLUTION DEGREE	2, per IEC 61131-2	MATERIAL COMPLIANCE	Compliant with REACH

GENERAL DATA

HOUSING MATERIAL	PPE	DIMENSIONS (H X W X D)	110.6 x 28.1 x 78.4 mm
WEIGHT	90 g	MTTF (25 °C)	155 years
COLOR	Light gray	APPROVALS	CE

6.4.1.8. 4/8-channel digital relay output module profile drawing

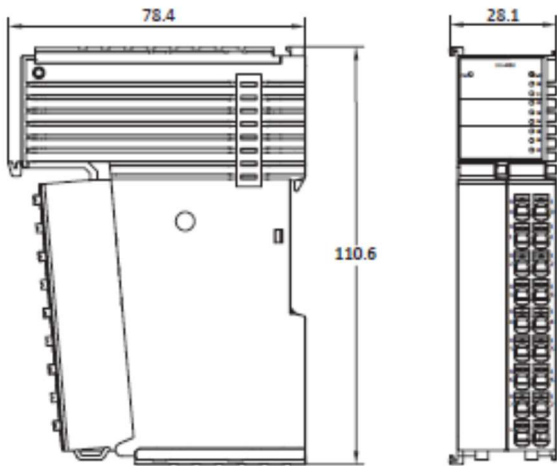

6.4.2. 16-channel digital input output module

6.4.2.1. 16-channel digital input module

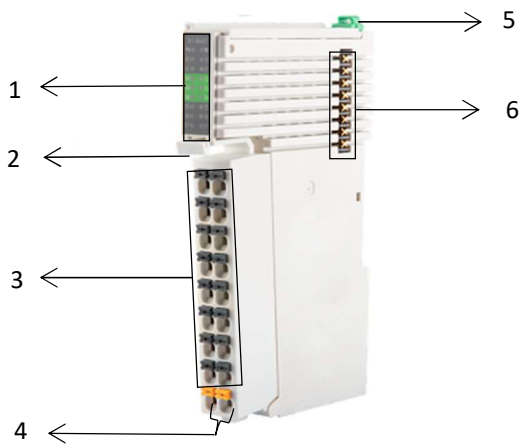

Item	Name	Function	Status
1	Module running indicator		
	PW	Backplane power indicator	Green: normal; Off: no backplane power
	MD	Module error indicator	Green: normal Red: Module channel error Green blinking: Connected but not configured; Red and green blinking: Backplane communication abnormal;
	00-07 10-17	Input signal indicators	Green: output 1 Off: output 0

2	Terminal disassembly device	Press the device to separate the terminal block from the module	-
3	IO input terminal 00-07/10-17	IO signal wiring	-
4	Common terminals	IO signal common terminals	0 V when the input signal is PNP, 24 V+ when the input signal is NPN
5	Module fixing device	Used to fix the module to the standard mounting rail	Pulling up: assembling position; Pressing down: locking position
6	Backplane interface	Backplane communication	-

6.4.2.2. 16 digital input module technical data

FX20-DI-BL60

ARTICLE PROPERTIES

PRODUCT TYPE	FX20 series modular I/O system digital input modules	PRODUCT GROUP	IP20 modular I/O system
DESCRIPTION	FX20-submodule 32-channel input PNP/ NPN, 24 V DC, IP20, DIN rail installation	PU	1 pc
		COUNTRY OF ORIGIN	CN

TECHNICAL DATA

NUMBER OF DIGITAL INPUTS	32	INPUT FILTERING DELAY	0 ms, 1 ms, 3 ms and 10 ms can be configured
INPUT TYPE	PNP / NPN	CURRENT CONSUMPTION (5 V)	60 mA
INPUT SIGNAL '0'	0 ... 5 V DC	PROCESS DATA LENGTH	4 bytes
INPUT SIGNAL '1'	18 ... 30 V DC	FAULT DIAGNOSIS METHOD	LED, communication message
INPUT CURRENT PER CHANNEL FOR SIGNAL '1'	Typ. 4 mA		

CONNECTION DATA

WIRE CONNECTION	Plug-in terminal block	STRIPPED LENGTHS	8 ... 10 mm 0.315 ... 0.394 in
CROSS SECTION	0.08 mm ² ... 2.5 mm ² AWG 28 ... 14		

ENVIRONMENTAL REQUIREMENTS

PROTECTION CLASS	IP20	ELECTRICAL FAST TRANSIENT (EFT)	Level A, per IEC 61000-4-4
MOUNTING TYPE	DIN-35 mm rail	ELECTRO-STATIC DISCHARGE (ESD)	Level A, per IEC 61000-4-2
AMBIENT TEMPERATURE	-5 ... +60 °C	SURGE TEST	Level A, per IEC 61000-4-5
STORAGE TEMPERATURE	-25 ... +70 °C	VIBRATION RESISTANCE	4 g, per IEC 60068-2-6

RELATIVE HUMIDITY	95%, non-condensing	SHOCK RESISTANCE	15 g, per IEC 60068-2-27
OPERATING ALTITUDE	0 ... 2000 m / 0 ... 6562 ft	EU ROHS COMPLIANCE STATUS	Yes
POLLUTION DEGREE	2, per IEC 61131-2	MATERIAL COMPLIANCE	Compliant with REACH

GENERAL DATA

HOUSING MATERIAL	PPE	DIMENSIONS (H X W X D)	110.6 x 28.1 x 78.4 mm
WEIGHT	128 g	MTTF (25 °C)	155 years
COLOR	Light gray	APPROVALS	CE

6.4.2.3. 16-channel digital output module

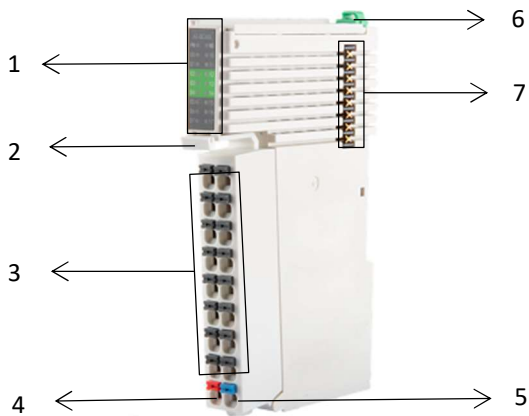

Item	Name	Function	Status
1	Module running indicator		
	PW	Backplane power indicator	Green: normal; Red: I/O power supply abnormal; Off: no backplane power
	MD	Module error indicator	Green: normal Red: Module channel error Green blinking: Connected but not configured; Red and green blinking: Backplane communication abnormal;
	00-07 10-17	Output signal indicator	Green: output "1" Off: output "0"
2	Terminal disassembly device	Press the device to separate the terminal block from the module	-
3	I/O output terminal 0-7,10-17	I/O signal wiring	-
4	24 V power terminal	24 V+	-
5	24 V power terminal	0 V	-

6	Module fixing device	Used to fix the module to the standard mounting rail	Pulling up: assembling position; Pressing down: locking position
7	Backplane expansion interface	Backplane communication	-

6.4.2.4. 16-channel digital output module technical data

FX20-DO-BH00

ARTICLE PROPERTIES

PRODUCT TYPE	FX20 series modular I/O system digital output modules	PRODUCT GROUP	IP20 modular I/O system
DESCRIPTION	FX20-submoduel 16-channel output PNP, 24 V DC, 0.5 A, IP20, DIN rail installation	PU	1 pc
		COUNTRY OF ORIGIN	CN

TECHNICAL DATA

NUMBER OF DIGITAL OUTPUTS	16	SWITCHING FREQUENCY	Max. 1 kHz (Resistive loads) Max. 1 Hz (Inductive loads) Max. 10 Hz (Lamps)
OUTPUT TYPE	PNP	OUTPUT HOLD	Supports, configured by PLC or web server
OUTPUT VOLTAGE	24 V DC	CURRENT CONSUMPTION (5 V)	60 mA
OUTPUT CURRENT	Max. 0.5 A per channel, total 4 A per module	PROCESS DATA LENGTH	2 bytes
OUTPUT LOAD TYPES	Resistive loads, inductive loads, lamps	FAULT DIAGNOSIS METHOD	LED, communication message

CONNECTION DATA

WIRE CONNECTION	Plug-in terminal block	STRIPPED LENGTHS	8 ... 10 mm 0.315 ... 0.394 in
CROSS SECTION	0.08 mm ² ... 2.5 mm ² AWG 28 ... 14		

ENVIRONMENTAL REQUIREMENTS

PROTECTION CLASS	IP20	ELECTRICAL FAST TRANSIENT (EFT)	Level A, per IEC 61000-4-4
MOUNTING TYPE	DIN-35 mm rail	ELECTRO-STATIC DISCHARGE (ESD)	Level A, per IEC 61000-4-2
AMBIENT TEMPERATURE	-5 ... +60 °C	SURGE TEST	Level A, per IEC 61000-4-5
STORAGE TEMPERATURE	-25 ... +70 °C	VIBRATION RESISTANCE	4 g, per IEC 60068-2-6
RELATIVE HUMIDITY	95%, non-condensing	SHOCK RESISTANCE	15 g, per IEC 60068-2-27
OPERATING ALTITUDE	0 ... 2000 m / 0 ... 6562 ft	EU ROHS COMPLIANCE STATUS	Yes
POLLUTION DEGREE	2, per IEC 61131-2	MATERIAL COMPLIANCE	Compliant with REACH

GENERAL DATA

HOUSING MATERIAL	PPE	DIMENSIONS (H X W X D)	110.6 x 15 x 78.4 mm
WEIGHT	63 g	MTTF (25 °C)	155 years
COLOR	Light gray	APPROVALS	CE

FX20-DO-BH50

ARTICLE PROPERTIES

PRODUCT TYPE	FX20 series modular I/O system digital output modules	PRODUCT GROUP	IP20 modular I/O system
DESCRIPTION	FX20-submodule 16-channel output NPN, 24 V DC, 0.5 A, IP20, DIN rail installation	PU	1 pc
		COUNTRY OF ORIGIN	CN

TECHNICAL DATA

NUMBER OF DIGITAL OUTPUTS	16	SWITCHING FREQUENCY	Max. 1 kHz (Resistive loads) Max. 1 Hz (Inductive loads) Max. 10 Hz (Lamps)
OUTPUT TYPE	NPN	OUTPUT HOLD	Supports, configured by PLC or web server
OUTPUT VOLTAGE	24 V DC	CURRENT CONSUMPTION (5 V)	60 mA
OUTPUT CURRENT	Max. 0.5 A per channel, total 4 A per module	PROCESS DATA LENGTH	2 bytes
OUTPUT LOAD TYPES	Resistive loads, inductive loads, lamps	FAULT DIAGNOSIS METHOD	LED, communication message

CONNECTION DATA

WIRE CONNECTION	Plug-in terminal block	STRIPPED LENGTHS	8 ... 10 mm 0.315 ... 0.394 in
CROSS SECTION	0.08 mm ² ... 2.5 mm ² AWG 28 ... 14		

ENVIRONMENTAL REQUIREMENTS

PROTECTION CLASS	IP20	ELECTRICAL FAST TRANSIENT (EFT)	Level A, per IEC 61000-4-4
MOUNTING TYPE	DIN-35 mm rail	ELECTRO-STATIC DISCHARGE (ESD)	Level A, per IEC 61000-4-2
AMBIENT TEMPERATURE	-5 ... +60 °C	SURGE TEST	Level A, per IEC 61000-4-5
STORAGE TEMPERATURE	-25 ... +70 °C	VIBRATION RESISTANCE	4 g, per IEC 60068-2-6
RELATIVE HUMIDITY	95%, non-condensing	SHOCK RESISTANCE	15 g, per IEC 60068-2-27
OPERATING ALTITUDE	0 ... 2000 m / 0 ... 6562 ft	EU ROHS COMPLIANCE STATUS	Yes
POLLUTION DEGREE	2, per IEC 61131-2	MATERIAL COMPLIANCE	Compliant with REACH

GENERAL DATA

HOUSING MATERIAL	PPE	DIMENSIONS (H X W X D)	110.6 x 15 x 78.4 mm
WEIGHT	63 g	MTTF (25 °C)	155 years
COLOR	Light gray	APPROVALS	CE

6.4.2.5. 16 digital input output module profile drawing

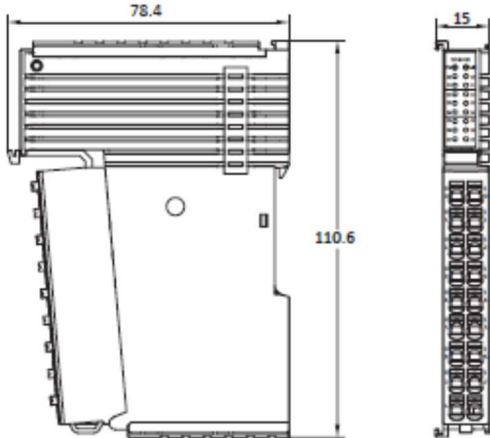

6.4.3. 32-channel digital input output module

6.4.3.1. 32-channel digital input module

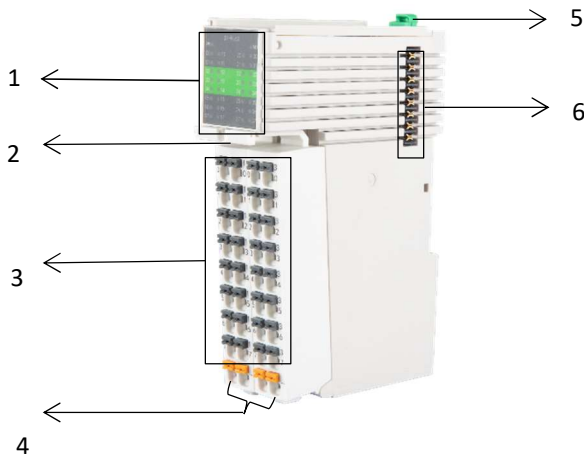

Item	Name	Function	Status
1	Module running indicator		
	PW	Backplane power indicator	Green: normal; Off: no backplane power
	MD	Module error indicator	Green: normal Red: Module channel error Green blinking: Connected but not configured; Red and green blinking: Backplane

			communication abnormal;
	00-07,10-17 20-27,30-37	Input signal indicator	Green: output "1" Off: output "0"
2	Terminal disassembly device	Press the device to separate the terminal block from the module	-
3	IO input terminal 00-07,10-17, 20-27,30-37	I/O signal wiring	-
4	Common terminals	I/O signal common terminals	0 V when the input signal is PNP, 24 V+ when the input signal is NPN
5	Module fixing device	Used to fix the module to the standard mounting rail	Pulling up: assembling position; Pressing down: locking position
6	Backplane expansion interface	Backplane communication	-

6.4.3.2. 32-channel digital input module technical data

FX20-DI-BL60

ARTICLE PROPERTIES

PRODUCT TYPE	FX20 series modular I/O system digital input modules	PRODUCT GROUP	IP20 modular I/O system
DESCRIPTION	FX20-submodule 32-channel input PNP/ NPN, 24 V DC, IP20, DIN rail installation	PU	1 pc
		COUNTRY OF ORIGIN	CN

TECHNICAL DATA

NUMBER OF DIGITAL INPUTS	32	INPUT FILTERING DELAY	0 ms, 1 ms, 3 ms and 10 ms can be configured
INPUT TYPE	PNP / NPN	CURRENT CONSUMPTION (5 V)	60 mA
INPUT SIGNAL '0'	0 ... 5 V DC	PROCESS DATA LENGTH	4 bytes
INPUT SIGNAL '1'	18 ... 30 V DC	FAULT DIAGNOSIS METHOD	LED, communication message
INPUT CURRENT PER CHANNEL FOR SIGNAL '1'	Typ. 4 mA		

CONNECTION DATA

WIRE CONNECTION	Plug-in terminal block	STRIPPED LENGTHS	8 ... 10 mm 0.315 ... 0.394 in
CROSS SECTION	0.08 mm ² ... 2.5 mm ² AWG 28 ... 14		

ENVIRONMENTAL REQUIREMENTS

PROTECTION CLASS	IP20	ELECTRICAL FAST TRANSIENT (EFT)	Level A, per IEC 61000-4-4
-------------------------	------	--	----------------------------

MOUNTING TYPE	DIN-35 mm rail	ELECTRO-STATIC DISCHARGE (ESD)	Level A, per IEC 61000-4-2
AMBIENT TEMPERATURE	-5 ... +60 °C	SURGE TEST	Level A, per IEC 61000-4-5
STORAGE TEMPERATURE	-25 ... +70 °C	VIBRATION RESISTANCE	4 g, per IEC 60068-2-6
RELATIVE HUMIDITY	95%, non-condensing	SHOCK RESISTANCE	15 g, per IEC 60068-2-27
OPERATING ALTITUDE	0 ... 2000 m / 0 ... 6562 ft	EU ROHS COMPLIANCE STATUS	Yes
POLLUTION DEGREE	2, per IEC 61131-2	MATERIAL COMPLIANCE	Compliant with REACH

GENERAL DATA

HOUSING MATERIAL	PPE	DIMENSIONS (H X W X D)	110.6 x 28.1 x 78.4 mm
WEIGHT	128 g	MTTF (25 °C)	155 years
COLOR	Light gray	APPROVALS	CE

6.4.3.3. 32-channel digital output module

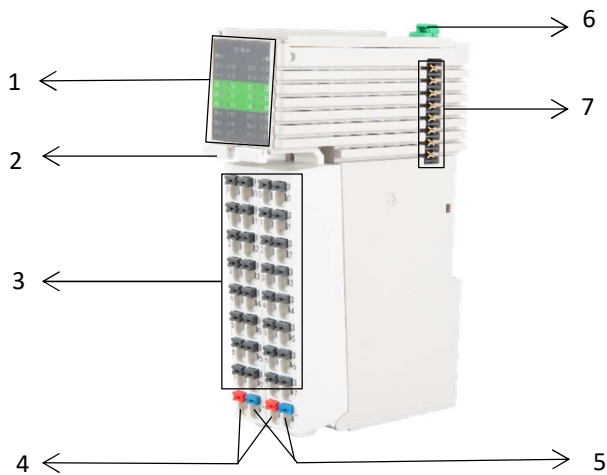

Item	Name	Function	Status
1	Module running indicators		
	PW	Backplane power indicator	Green: normal; Red: I/O power supply abnormal; Off: no backplane power
	MD	Module error indicator	Green: normal Red: Module channel error Green blinking: Connected but not configured; Red and green blinking: Backplane communication abnormal;
	00-07,10-17 20-27,30-37	Output signal indicator	Green: output "1" Off: output "0"
2	Terminal disassembly device	Press the device to separate the terminal block from the module	-

3	I/O output terminal 00-07,10-17, 20-27,30-37	I/O signal wiring	-
4	24 V power terminal	24V+	-
5	24 V power terminal	0V	-
6	Module fixing device	Used to fix the module to the standard mounting rail	Pulling up: assembling position; Pressing down: locking position
7	Backplane bus interface	Backplane communication	-

6.4.3.4. 32-channel digital output module technical data

FX20-DO-BL00

ARTICLE PROPERTIES

PRODUCT TYPE	FX20 series modular I/O system digital output modules	PRODUCT GROUP	IP20 modular I/O system
DESCRIPTION	FX20-submodule 32-channel output PNP, 24 V DC, 0.5 A, IP20, DIN rail installation	PU	1 pc
		COUNTRY OF ORIGIN	CN

TECHNICAL DATA

NUMBER OF DIGITAL OUTPUTS	32	SWITCHING FREQUENCY	Max. 1 kHz (Resistive loads) Max. 1 Hz (Inductive loads) Max. 10 Hz (Lamps)
OUTPUT TYPE	PNP	OUTPUT HOLD	Supports, configured by PLC or web server
OUTPUT VOLTAGE	24 V DC	CURRENT CONSUMPTION (5 V)	60 mA
OUTPUT CURRENT	Max. 0.5 A per channel, total 4 A per module	PROCESS DATA LENGTH	4 bytes
OUTPUT LOAD TYPES	Resistive loads, inductive loads, lamps	FAULT DIAGNOSIS METHOD	LED, communication message

CONNECTION DATA

WIRE CONNECTION	Plug-in terminal block	STRIPPED LENGTHS	8 ... 10 mm 0.315 ... 0.394 in
CROSS SECTION	0.08 mm ² ... 2.5 mm ² AWG 28 ... 14		

ENVIRONMENTAL REQUIREMENTS

PROTECTION CLASS	IP20	ELECTRICAL FAST TRANSIENT (EFT)	Level A, per IEC 61000-4-4
MOUNTING TYPE	DIN-35 mm rail	ELECTRO-STATIC DISCHARGE (ESD)	Level A, per IEC 61000-4-2
AMBIENT TEMPERATURE	-5 ... +60 °C	SURGE TEST	Level A, per IEC 61000-4-5
STORAGE TEMPERATURE	-25 ... +70 °C	VIBRATION RESISTANCE	4 g, per IEC 60068-2-6

RELATIVE HUMIDITY	95%, non-condensing	SHOCK RESISTANCE	15 g, per IEC 60068-2-27
OPERATING ALTITUDE	0 ... 2000 m / 0 ... 6562 ft	EU ROHS COMPLIANCE STATUS	Yes
POLLUTION DEGREE	2, per IEC 61131-2	MATERIAL COMPLIANCE	Compliant with REACH

GENERAL DATA

HOUSING MATERIAL	PPE	DIMENSIONS (H X W X D)	110.6 x 28.1 x 78.4 mm
WEIGHT	128 g	MTTF (25 °C)	155 years
COLOR	Light gray	APPROVALS	CE

FX20-DO-BL50

ARTICLE PROPERTIES

PRODUCT TYPE	FX20 series modular I/O system digital output modules	PRODUCT GROUP	IP20 modular I/O system
DESCRIPTION	FX20-submodule 32-channel output NPN, 24 V DC, 0.5 A, IP20, DIN rail installation	PU	1 pc
		COUNTRY OF ORIGIN	CN

TECHNICAL DATA

NUMBER OF DIGITAL OUTPUTS	32	SWITCHING FREQUENCY	Max. 1 kHz (Resistive loads) Max. 1 Hz (Inductive loads) Max. 10 Hz (Lamps)
OUTPUT TYPE	NPN	OUTPUT HOLD	Supports, configured by PLC or web server
OUTPUT VOLTAGE	24 V DC	CURRENT CONSUMPTION (5 V)	60 mA
OUTPUT CURRENT	Max. 0.5 A per channel, total 4 A per module	PROCESS DATA LENGTH	4 bytes
OUTPUT LOAD TYPES	Resistive loads, inductive loads, lamps	FAULT DIAGNOSIS METHOD	LED, communication message

CONNECTION DATA

WIRE CONNECTION	Plug-in terminal block	STRIPPED LENGTHS	8 ... 10 mm 0.315 ... 0.394 in
CROSS SECTION	0.08 mm ² ... 2.5 mm ² AWG 28 ... 14		

ENVIRONMENTAL REQUIREMENTS

PROTECTION CLASS	IP20	ELECTRICAL FAST TRANSIENT (EFT)	Level A, per IEC 61000-4-4
MOUNTING TYPE	DIN-35 mm rail	ELECTRO-STATIC DISCHARGE (ESD)	Level A, per IEC 61000-4-2
AMBIENT TEMPERATURE	-5 ... +60 °C	SURGE TEST	Level A, per IEC 61000-4-5
STORAGE TEMPERATURE	-25 ... +70 °C	VIBRATION RESISTANCE	4 g, per IEC 60068-2-6
RELATIVE HUMIDITY	95%, non-condensing	SHOCK RESISTANCE	15 g, per IEC 60068-2-27

OPERATING ALTITUDE	0 ... 2000 m / 0 ... 6562 ft	EU ROHS COMPLIANCE STATUS	Yes
POLLUTION DEGREE	2, per IEC 61131-2	MATERIAL COMPLIANCE	Compliant with REACH

GENERAL DATA

HOUSING MATERIAL	PPE	DIMENSIONS (H X W X D)	110.6 x 28.1 x 78.4 mm
WEIGHT	128 g	MTTF (25 °C)	155 years
COLOR	Light gray	APPROVALS	CE

6.4.3.5. 32-channel digital input/output module profile drawing

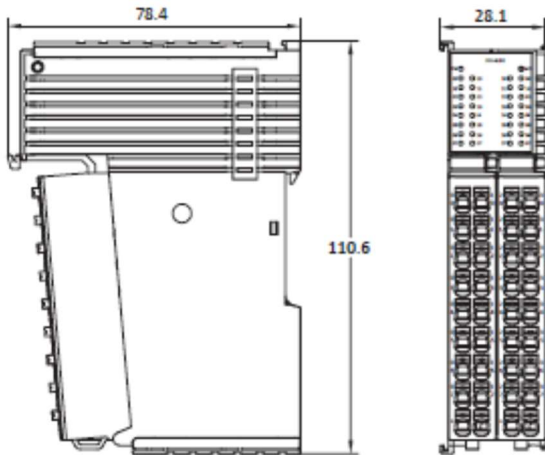

6.4.4. 4-channel analog input/output module

6.4.4.1. 4-channel analog input module

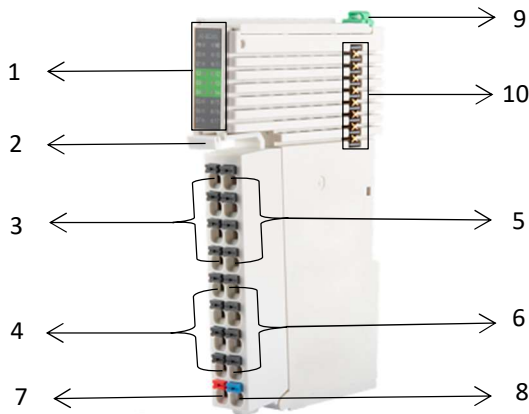

Item	Name	Function	Status
1	Module running indicators		
	PW	Backplane power indicator	Green: normal; Red: I/O power supply abnormal; Off: no backplane power
	MD	Module error indicator	Green: normal

			Red: Module channel error Green blinking: Connected but not configured; Red and green blinking: Backplane communication abnormal;
	C1-C4	Input signal indicator	Green: input normal Red: input over range
2	Terminal disassembly device	Press the device to separate the terminal block from the module	-
3	Analog input channel 0	Analog input	-
4	Analog input channel 1	Analog input	-
5	Analog input channel 2	Analog input	-
6	Analog input channel 3	Analog input	-
7	24 V power terminal	24V+	-
8	24 V power terminal	0V	-
9	Module fixing device	Used to fix the module to the standard mounting rail	Pulling up: assembling position; Pressing down: locking position
10	Backplane bus interface	Backplane communication	-

6.4.4.2. 4-channel analog input module technical data

FX20-AI-BD60

ARTICLE PROPERTIES

PRODUCT TYPE	FX20 series modular I/O system analog input modules	PRODUCT GROUP	IP20 modular I/O system
DESCRIPTION	FX20-submodule 4-channel analog input, voltage / current types, 24 V DC, IP20, DIN rail installation	PU	1 pc
		COUNTRY OF ORIGIN	CN

TECHNICAL DATA

NUMBER OF ANALOG INPUTS	4	MEASURING ACCURACY	± 0.2 %
INPUT TYPE	0 ... 10 V, ± 10 V, 1 ... 5 V, 0/4 ... 20 mA, ±20 mA	OPERATING VOLTAGE	24 V DC
INPUT IMPEDANCE	Current type: 250 Ω Voltage type: 1 MΩ	CURRENT CONSUMPTION (5 V)	60 mA
INPUT RESOLUTION	16 bits	PROCESS DATA LENGTH	8 bytes
CONVERTING TIME	3 ms	FAULT DIAGNOSIS METHOD	LED, communication message

CONNECTION DATA

WIRE CONNECTION	Plug-in terminal block	STRIPPED LENGTHS	8 ... 10 mm 0.315 ... 0.394 in
------------------------	------------------------	-------------------------	-----------------------------------

CROSS SECTION 0.08 ... 2.5 mm²
AWG 28 ... 14

ENVIRONMENTAL REQUIREMENTS

PROTECTION CLASS	IP20	ELECTRICAL FAST TRANSIENT (EFT)	Level A, per IEC 61000-4-4
MOUNTING TYPE	DIN-35 mm rail	ELECTRO-STATIC DISCHARGE (ESD)	Level A, per IEC 61000-4-2
AMBIENT TEMPERATURE	-5 ... +60 °C	SURGE TEST	Level A, per IEC 61000-4-5
STORAGE TEMPERATURE	-25 ... +70 °C	VIBRATION RESISTANCE	4 g, per IEC 60068-2-6
RELATIVE HUMIDITY	95%, non-condensing	SHOCK RESISTANCE	15 g, per IEC 60068-2-27
OPERATING ALTITUDE	0 ... 2000 m / 0 ... 6562 ft	EU ROHS COMPLIANCE STATUS	Yes
POLLUTION DEGREE	2, compliant with IEC 61131-2	MATERIAL COMPLIANCE	Compliant with REACH

GENERAL DATA

HOUSING MATERIAL	PPE	DIMENSIONS (H X W X D)	110.6 x 15 x 78.4 mm
WEIGHT	63 g	MTTF (25 °C)	196 years
COLOR	Light gray	APPROVALS	CE

6.4.4.3. 4-channel analog output module

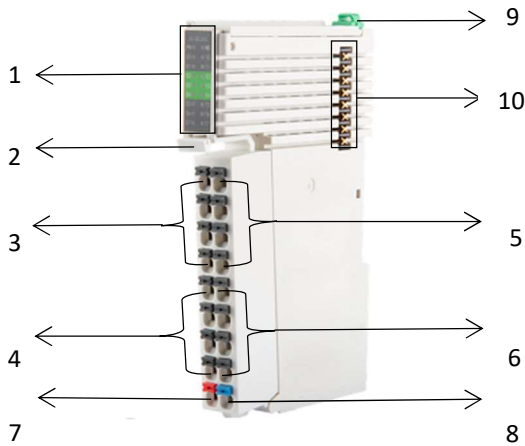

Item	Name	Function	Status
1	Module running indicators		
	PW	Backplane power indicator	Green: normal; Red: I/O power supply abnormal; Off: no backplane power
	MD	Module error indicator	Green: normal Red: Module channel error

			Green blinking: Connected but not be configured; Red and green blinking: Backplane communication abnormal.
	C1-C4	Output signal indicator	Green: output normal Red: output over range
2	Terminal disassembly device	Press the device to separate the terminal block from the module	-
3	Analog output 0	Analog output	-
4	Analog output 1	Analog output	-
5	Analog output 2	Analog output	-
6	Analog output 3	Analog output	-
7	24 V power terminal	24 V+	-
8	24 V power terminal	0 V	-
9	Module fixing device	Used to fix the module to the standard mounting rail	Pulling up: assembling position; Pressing down: locking position
10	Backplane bus interface	Backplane communication	

6.4.4.4. 4-channel analog output module technical data

FX20-AO-BD60

ARTICLE PROPERTIES

PRODUCT TYPE	FX20 series modular I/O system analog output modules	PRODUCT GROUP	IP20 modular I/O system
DESCRIPTION	FX20-submodule 4-channel analog output, voltage/current types, 24 V DC, IP20, DIN rail installation	PU	1 pc
		COUNTRY OF ORIGIN	CN

TECHNICAL DATA

NUMBER OF ANALOG INPUTS	4	OPERATING VOLTAGE	24 V DC
OUTPUT TYPE	0 ... 10 V, ± 10 V, 1 ... 5 V, 0/4 ... 20 mA	CURRENT CONSUMPTION (5 V)	60 mA
OUTPUT RESOLUTION	16 bits	PROCESS DATA LENGTH	8 bytes
CONVERTING TIME	2 ms	FAULT DIAGNOSIS METHOD	LED, communication message
MEASURING ACCURACY	± 0.2 %		

CONNECTION DATA

WIRE CONNECTION	Plug-in terminal block	STRIPPED LENGTHS	8 ... 10 mm 0.315 ... 0.394 in
CROSS SECTION	0.08 mm ² ... 2.5 mm ² AWG 28 ... 14		

ENVIRONMENTAL REQUIREMENTS

PROTECTION CLASS	IP20	ELECTRICAL FAST TRANSIENT (EFT)	Level A, per IEC 61000-4-4
MOUNTING TYPE	DIN-35 mm rail	ELECTRO-STATIC DISCHARGE (ESD)	Level A, per IEC 61000-4-2
AMBIENT TEMPERATURE	-5 ... +60 °C	SURGE TEST	Level A, per IEC 61000-4-5
STORAGE TEMPERATURE	-25 ... +70 °C	VIBRATION RESISTANCE	4 g, per IEC 60068-2-6
RELATIVE HUMIDITY	95%, non-condensing	SHOCK RESISTANCE	15 g, per IEC 60068-2-27
OPERATING ALTITUDE	0 ... 2000 m / 0 ... 6562 ft	EU ROHS COMPLIANCE STATUS	Yes
POLLUTION DEGREE	2, per IEC 61131-2	MATERIAL COMPLIANCE	Compliant with REACH

GENERAL DATA

HOUSING MATERIAL	PPE	DIMENSIONS (H X W X D)	110.6 x 15 x 78.4 mm
WEIGHT	63 g	MTTF (25 °C)	196 years
COLOR	Light gray	APPROVALS	CE

6.4.4.5. 4-channel analog input output module profile drawing

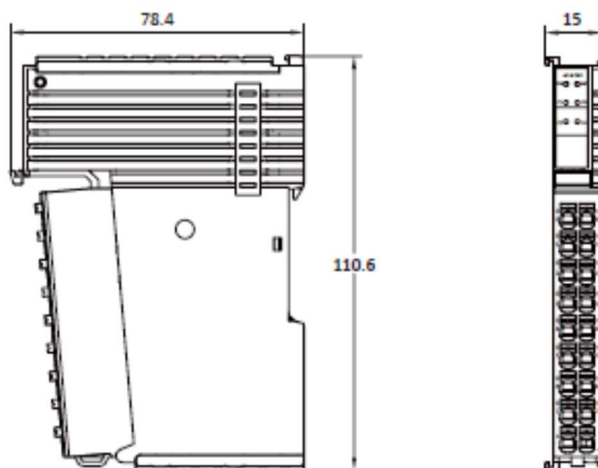

6.4.5. 8-channel analog input output modules

6.4.5.1. 8-channel analog input modules

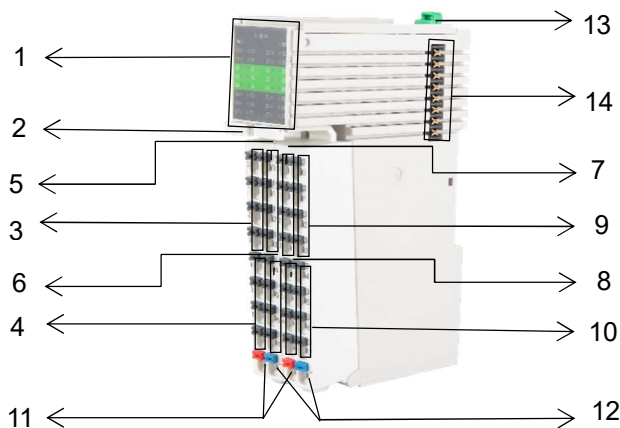

Item	Name	Function	Status
1	Module running indicators		
	PW	Backplane power indicator	Green: normal; Red: I/O power supply abnormal; Off: no backplane power
	MD	Module error indicator	Green: normal Red: Module channel error Green blinking: Connected but not configured; Red and green blinking: Backplane communication abnormal;
	C1-C8	Input signal indicator	Green: input normal Red: input over range
2	Terminal disassembly device	Press the device to separate the terminal block from the module	-
3	Analog input channel 0	Analog input	-
4	Analog input channel 1	Analog input	-
5	Analog input channel 2	Analog input	-
6	Analog input channel 3	Analog input	-
7	Analog input channel 4	Analog input	-
8	Analog input channel 5	Analog input	-
9	Analog input channel 6	Analog input	-
10	Analog input channel 7	Analog input	-
11	24 V power terminal	24 V+	-
12	24 V power terminal	0 V	-
13	Module fixing device	Used to fix the module to the standard mounting rail	Pulling up: assembling position; Pressing down: locking position
14	Backplane bus interface	Backplane communication	-

6.4.5.2. 8-channel analog input module technical data

FX20-AI-BF60

ARTICLE PROPERTIES

PRODUCT TYPE	FX20 series modular I/O system analog input modules	PRODUCT GROUP	IP20 modular I/O system
DESCRIPTION	FX20-submodule 8-channel analog input, voltage / current types, 24 V DC, IP20, DIN rail installation	PU	1 pc
		COUNTRY OF ORIGIN	CN

TECHNICAL DATA

NUMBER OF ANALOG INPUTS	8	MEASURING ACCURACY	± 0.2 %
--------------------------------	---	---------------------------	---------

INPUT TYPE	0 ... 10 V, ± 10 V, 1 ... 5 V, 0/4 ... 20 mA, ± 20 mA	OPERATING VOLTAGE	24 V DC
INPUT IMPEDANCE	Current type: 250 Ω Voltage type: 1 MΩ	CURRENT CONSUMPTION (5 V)	60 mA
INPUT RESOLUTION	16 bits	PROCESS DATA LENGTH	16 bytes
CONVERTING TIME	3 ms	FAULT DIAGNOSIS METHOD	LED, communication message

CONNECTION DATA

WIRE CONNECTION	Plug-in terminal block	STRIPPED LENGTHS	8 ... 10 mm 0.315 ... 0.394 in
CROSS SECTION	0.08 mm ² ... 2.5 mm ² AWG 28 ... 14		

ENVIRONMENTAL REQUIREMENTS

PROTECTION CLASS	IP20	ELECTRICAL FAST TRANSIENT (EFT)	Level A, per IEC 61000-4-4
MOUNTING TYPE	DIN-35 mm rail	ELECTRO-STATIC DISCHARGE (ESD)	Level A, per IEC 61000-4-2
AMBIENT TEMPERATURE	-5 ... +60 °C	SURGE TEST	Level A, per IEC 61000-4-5
STORAGE TEMPERATURE	-25 ... +70 °C	VIBRATION RESISTANCE	4 g, per IEC 60068-2-6
RELATIVE HUMIDITY	95%, non-condensing	SHOCK RESISTANCE	15 g, per IEC 60068-2-27
OPERATING ALTITUDE	0 ... 2000 m / 0 ... 6562 ft	EU ROHS COMPLIANCE STATUS	Yes
POLLUTION DEGREE	2, per IEC 61131-2	MATERIAL COMPLIANCE	Compliant with REACH

GENERAL DATA

HOUSING MATERIAL	PPE	DIMENSIONS (H X W X D)	110.6 x 28.1 x 78.4 mm
WEIGHT	128 g	MTTF (25 °C)	196 years
COLOR	Light gray	APPROVALS	CE

6.4.5.3. 8-channel analog output module

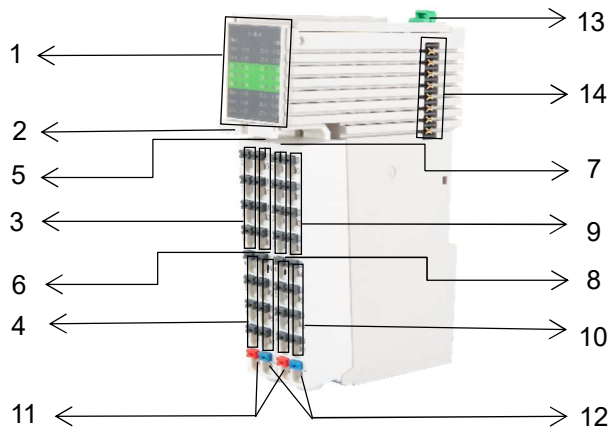

Item	Name	Function	Status
------	------	----------	--------

1	Module running indicator		
	PW	Backplane power indicator	Green: normal; Red: I/O power supply abnormal; Off: no backplane power
	MD	Module error indicator	Green: normal Red: Module channel error Green blinking: Connected but not configured; Red and green blinking: Backplane communication abnormal;
	C1-C8	Output signal indicator	Green: output normal Red: output over range
2	Terminal disassembly device	Press the device to separate the terminal block from the module	-
3	Analog output 0	Analog output	-
4	Analog output 1	Analog output	-
5	Analog output 2	Analog output	-
6	Analog output 3	Analog output	-
7	Analog output 4	Analog output	-
8	Analog output 5	Analog output	-
9	Analog output 6	Analog output	-
10	Analog output 7	Analog output	-
11	24 V power terminal	24 V+	-
12	24 V power terminal	0 V	-
13	Module fixing device	Used to fix the module to the standard mounting rail	Pulling up: assembling position; Pressing down: locking position
14	Backplane bus interface	Backplane communication	-

6.4.5.4. 8-channel analog output module technical data

FX20-AO-BF60

ARTICLE PROPERTIES

PRODUCT TYPE	FX20 series modular I/O system analog output modules	PRODUCT GROUP	IP20 modular I/O system
DESCRIPTION	FX20-submodule 8-channel analog output, voltage / current types, 24 V DC, IP20, DIN rail installation	PU	1 pc
		COUNTRY OF ORIGIN	CN

TECHNICAL DATA

NUMBER OF ANALOG INPUTS	8	OPERATING VOLTAGE	24 V DC
OUTPUT TYPE	0 ... 10 V, ± 10 V, 1 ... 5 V,	CURRENT CONSUMPTION (5 V)	60 mA

OUTPUT RESOLUTION	0/4 ... 20 mA	PROCESS DATA LENGTH	16 bytes
CONVERTING TIME	16 bits	FAULT DIAGNOSIS METHOD	LED, communication message
MEASURING ACCURACY	2 ms ± 0.2 %		

CONNECTION DATA

WIRE CONNECTION	Plug-in terminal block	STRIPPED LENGTHS	8 ... 10 mm, 0.315 ... 0.394 in
CROSS SECTION	0.08 mm ² ... 2.5 mm ² , AWG 28 ... 14		

ENVIRONMENTAL REQUIREMENTS

PROTECTION CLASS	IP20	ELECTRO-STATIC DISCHARGE (ESD)	Level A, per IEC 61000-4-2
MOUNTING TYPE	DIN-35 mm rail	SURGE TEST	Level A, per IEC 61000-4-5
AMBIENT TEMPERATURE	-5 ... +60 °C	VIBRATION RESISTANCE	4 g, per IEC 60068-2-6
STORAGE TEMPERATURE	-25 ... +70 °C	SHOCK RESISTANCE	15 g, per IEC 60068-2-27
RELATIVE HUMIDITY	95%, non-condensing	EU ROHS COMPLIANCE STATUS	Yes
OPERATING ALTITUDE	0 ... 2000 m / 0 ... 6562 ft	MATERIAL COMPLIANCE	Compliant with REACH
POLLUTION DEGREE	2, per IEC 61131-2	DIMENSIONS (H X W X D)	110.6 x 28 x 78.4 mm
ELECTRICAL FAST TRANSIENT (EFT)	Level A, per IEC 61000-4-4	CONFORMITY MARKING	CE

GENERAL DATA

HOUSING MATERIAL	PPE	DIMENSIONS (H X W X D)	110.6 x 28 x 78.4 mm
WEIGHT	63 g	MTTF (25 °C)	196 years
COLOR	Light gray	APPROVALS	CE

6.4.5.5. 8-channel analog input/output module profile drawing

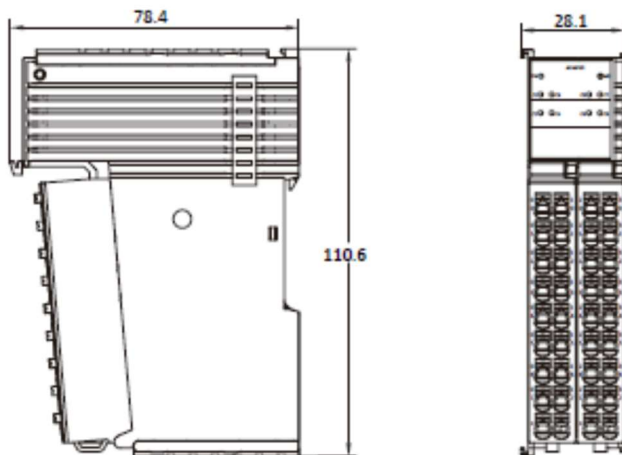

6.4.6. 4-channel temperature measurement modules

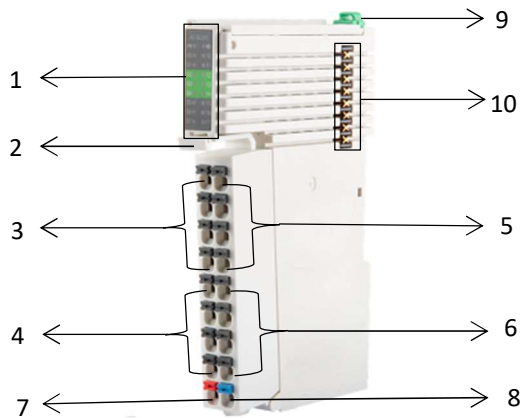

Item	Name	Function	Status
1	Module running indicators		
	PW	Backplane power indicator	Green: normal; Red: I/O power supply abnormal; Off: no backplane power
	MD	Module error indicator	Green: normal Red: Module channel error Green blinking: Connected but not configured; Red and green blinking: Backplane communication abnormal;
	C1-C4	Temperature measurement signal indicator	Green: input normal Red: input over range
2	Terminal disassembly device	Press the device to separate the terminal block from the module	-
3	Temp measurement channel 0	Analog output	-
4	Temp measurement channel 1	Analog output	-
5	Temp measurement channel 2	Analog output	-
6	Temp measurement channel 3	Analog output	-
7	24 V power terminal	24V+	-
8	24 V power terminal	0V	-
9	Module fixing device	Used to fix the module to the standard mounting rail	Pulling up: assembling position; Pressing down: locking position
10	Backplane bus interface	Backplane communication	-

6.4.6.1. 4-channel temperature measurement modules technical data

FX20-AI-BD80

ARTICLE PROPERTIES

PRODUCT TYPE	FX20 series modular I/O system analog input modules	PRODUCT GROUP	IP20 modular I/O system
DESCRIPTION	FX20-submodule 4-channel RTD measurement, 24 V DC, IP20, DIN rail installation	PU	1 pc
		COUNTRY OF ORIGIN	CN

TECHNICAL DATA

NUMBER OF ANALOG INPUTS	4	MEASUREMENT ACCURACY	Within 2 °C
INPUT TYPE	Thermal resistance, (2-wire, 3-wire): PT100, PT1000	OPERATING VOLTAGE	24 V DC
INPUT RESOLUTION	16 bits	CURRENT CONSUMPTION (5 V)	60 mA
CONVERTING TIME(TYP.)	320 ms	PROCESS DATA LENGTH	8 bytes
SENSITIVITY	0.1 °C	FAULT DIAGNOSIS METHOD	LED, communication message

CONNECTION DATA

WIRE CONNECTION	Plug-in terminal block	STRIPPED LENGTHS	8 ... 10 mm, 0.315 ... 0.394 in
CROSS SECTION	0.08 mm ² ... 2.5 mm ² , AWG 28 ... 14		

ENVIRONMENTAL REQUIREMENTS

PROTECTION CLASS	IP20	ELECTRICAL FAST TRANSIENT (EFT)	Level A, per IEC 61000-4-4
MOUNTING TYPE	DIN-35 mm rail	ELECTRO-STATIC DISCHARGE (ESD)	Level A, per IEC 61000-4-2
AMBIENT TEMPERATURE	-5 ... +60 °C	SURGE TEST	Level A, per IEC 61000-4-5
STORAGE TEMPERATURE	-25 ... +70 °C	VIBRATION RESISTANCE	4 g, per IEC 60068-2-6
RELATIVE HUMIDITY	95%, non-condensing	VIBRATION RESISTANCE	4 g, per IEC 60068-2-6
OPERATING ALTITUDE	0 ... 2000 m / 0 ... 6562 ft	SHOCK RESISTANCE	15 g, per IEC 60068-2-27
HOUSING MATERIAL	PPE	EU ROHS COMPLIANCE STATUS	Yes
POLLUTION DEGREE	2, compliant with IEC 61131-2	MATERIAL COMPLIANCE	Compliant with REACH

GENERAL DATA

HOUSING MATERIAL	PPE	DIMENSIONS (H X W X D)	110.6 x 15 x 78.4 mm
WEIGHT	63 g	MTTF (25 °C)	196 years
COLOR	Light gray	APPROVALS	CE

FX20-AI-BD90

ARTICLE PROPERTIES

PRODUCT TYPE	FX20 series modular I/O system analog input modules	PRODUCT GROUP	IP20 modular I/O system
DESCRIPTION	FX20-submodule 4-channel TC measurement, 24 V DC, IP20, DIN rail installation	PU	1 pc
		COUNTRY OF ORIGIN	CN

TECHNICAL DATA

NUMBER OF ANALOG INPUTS	4	MEASUREMENT ACCURACY	Within 2 °C
INPUT TYPE	Thermocouples: J, K, T, N, E types	OPERATING VOLTAGE	24 V DC
INPUT RESOLUTION	16 bits	CURRENT CONSUMPTION (5 V)	60 mA
CONVERTING TIME(TYP.)	320 ms	PROCESS DATA LENGTH	8 bytes
SENSITIVITY	0.1 °C	FAULT DIAGNOSIS METHOD	LED, communication message

CONNECTION DATA

WIRE CONNECTION	Plug-in terminal block	STRIPPED LENGTHS	8 ... 10 mm, 0.315 ... 0.394 in
CROSS SECTION	0.08 mm ² ... 2.5 mm ² , AWG 28 ... 14		

ENVIRONMENTAL REQUIREMENTS

PROTECTION CLASS	IP20	ELECTRICAL FAST TRANSIENT (EFT)	Level A, per IEC 61000-4-4
MOUNTING TYPE	DIN-35 mm rail	ELECTRO-STATIC DISCHARGE (ESD)	Level A, per IEC 61000-4-2
AMBIENT TEMPERATURE	-5 ... +60 °C	SURGE TEST	Level A, per IEC 61000-4-5
STORAGE TEMPERATURE	-25 ... +70 °C	VIBRATION RESISTANCE	4 g, per IEC 60068-2-6
RELATIVE HUMIDITY	95%, non-condensing	SHOCK RESISTANCE	15 g, per IEC 60068-2-27
OPERATING ALTITUDE	0 ... 2000 m / 0 ... 6562 ft	EU ROHS COMPLIANCE STATUS	Yes
POLLUTION DEGREE	2, per IEC 61131-2	MATERIAL COMPLIANCE	Compliant with REACH

GENERAL DATA

HOUSING MATERIAL	PPE	DIMENSIONS (H X W X D)	110.6 x 15 x 78.4 mm
WEIGHT	63 g	MTTF (25 °C)	196 years
COLOR	Light gray	APPROVALS	CE

6.4.6.2. 4-channel temperature measurement module profile drawing

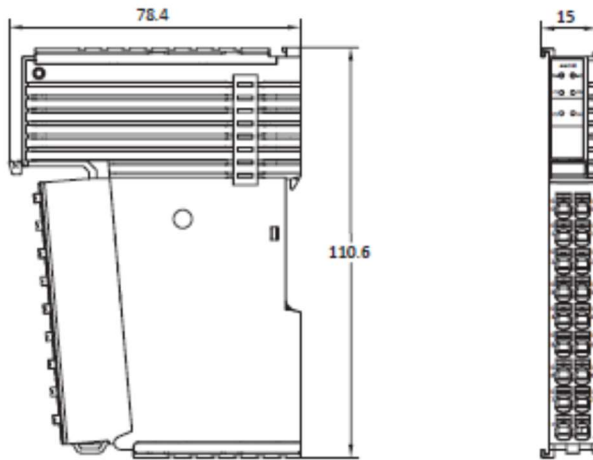

6.4.7. Auxiliary power module

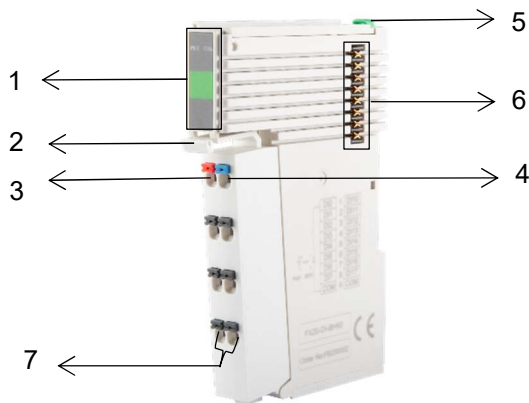

Item	Name	Function	Status
1	Module running indicators		
	PW	24 V power indicator	Green: normal Red: 24V overvoltage
	Us	Backplane power indicator	Green: normal Off: no power supply
2	Terminal disassembly device	Press the device to separate the terminal block from the module	-
3	External power supply terminal	24 V+	-
4	External power supply terminal	0 V	-
5	Module fixing device	Used to fix the module to the standard mounting rail	Pulling up: assembling position; Pressing down: locking position
6	Backplane bus interface	Backplane communication	-
7	Grounding terminal	PE	-

6.4.7.1. Auxiliary power module technical data

FX20-PS-AB00

ARTICLE PROPERTIES

PRODUCT TYPE	FX20 series modular I/O system auxiliary power supply module	PRODUCT GROUP	IP20 modular I/O system
DESCRIPTION	FX20-submodul power supply, 24 V DC, IP20, DIN rail installation, overcurrent and reverse polarity protection	PU	1 pc
		COUNTRY OF ORIGIN	CN

TECHNICAL DATA

INPUT VOLTAGE	24 V DC	OUTPUT CURRENT	Max. 3 A
INPUT VOLTAGE RANGE	20.4.....28.8 V DC	POWER PROTECTION	Overcurrent protection, power polarity reverse protection
OUTPUT VOLTAGE	5 V DC	EFFICIENCY	95%

CONNECTION DATA

WIRE CONNECTION	Plug-in terminal block	STRIPPED LENGTHS	8 ... 10 mm 0.315 ... 0.394 in
CROSS SECTION	0.08 mm ² ... 2.5 mm ² AWG 28 ... 14		

ENVIRONMENTAL REQUIREMENTS

PROTECTION CLASS	IP20	ELECTRICAL FAST TRANSIENT (EFT)	Level A, per IEC 61000-4-4
MOUNTING TYPE	DIN-35 mm rail	ELECTRO-STATIC DISCHARGE (ESD)	Level A, per IEC 61000-4-2
AMBIENT TEMPERATURE	-5 ... +60 °C	SURGE TEST	Level A, per IEC 61000-4-5
STORAGE TEMPERATURE	-25 ... +70 °C	VIBRATION RESISTANCE	4 g, per IEC 60068-2-6
RELATIVE HUMIDITY	95%, non-condensing	SHOCK RESISTANCE	15 g, per IEC 60068-2-27
OPERATING ALTITUDE	0 ... 2000 m / 0 ... 6562 ft	EU ROHS COMPLIANCE STATUS	Yes
POLLUTION DEGREE	2, per IEC 61131-2	MATERIAL COMPLIANCE	Compliant with REACH

GENERAL DATA

HOUSING MATERIAL	PPE	DIMENSIONS (H X W X D)	110.6 x 15 x 78.4 mm
WEIGHT	63 g	APPROVALS	CE
COLOR	Light gray		

6.4.7.2. Auxiliary power module profile drawing

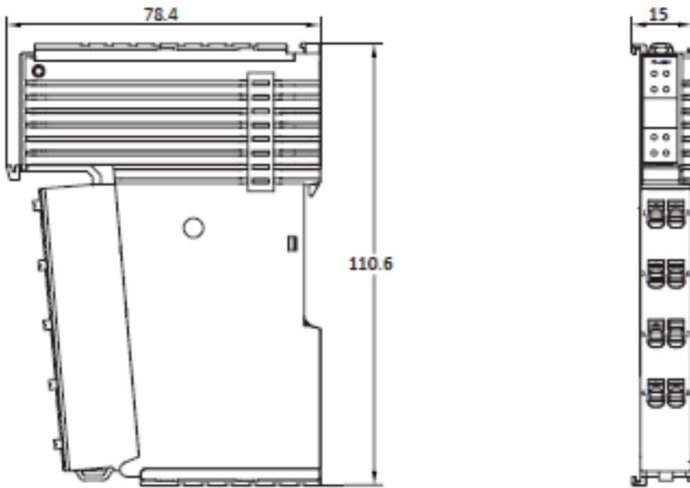

7. Mechanical installation and disassembly

7.1. Installation location and minimum installation distance

The installation position and reserved space are shown in the following figure. Install the installation guide rail horizontally to the designated installation position, and the connection surface of the connector and I/O modules must face forward.

The installation position should maintain a certain distance from adjacent electrical components or cabinets to facilitate heat dissipation. The recommended minimum installation clearance can refer to the markings in the above figure.

Ensure that FX20 is ventilated from bottom to top and achieve optimal cooling through convective ventilation.

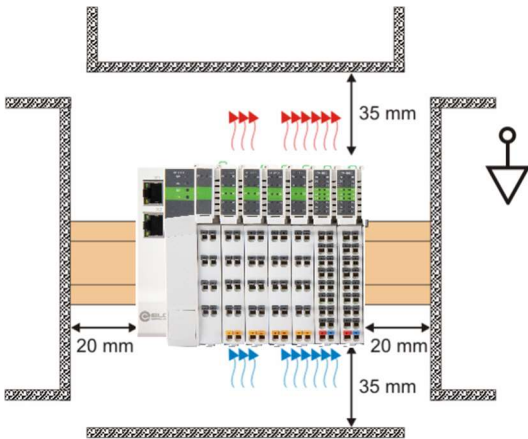

7.1. FX20 adapter installation

The installation is carried out according to the following steps:



During installation, align the module with the DIN rail and press the fixing device in the direction indicated by the arrow. After installation, there will be a noticeable clicking sound; change the position of the locking device slightly; after installing the module properly, make the locking device clamp the upper edge of the rail; to avoid damaging the product, do not apply excessive force.

7.2. FX20 submodules installation

After the installation of the adapter, the function modules can be sequentially inserted from the right side of the adapter. Before the insertion, ensure to pull out the fixing device and aligned with the two slots on the module.



i Caution!

The end cover is only to protect the backplane bus interface of the end module, and it is packaged and shipped together with the adapter.

7.3. Modules disassembly

Use a flat screwdriver or similar tool to pry up the locking device on the rail, and then pull the module away from the DIN rail.



The wiring terminals of all modules can be removed separately to facilitate module replacement, as follows:

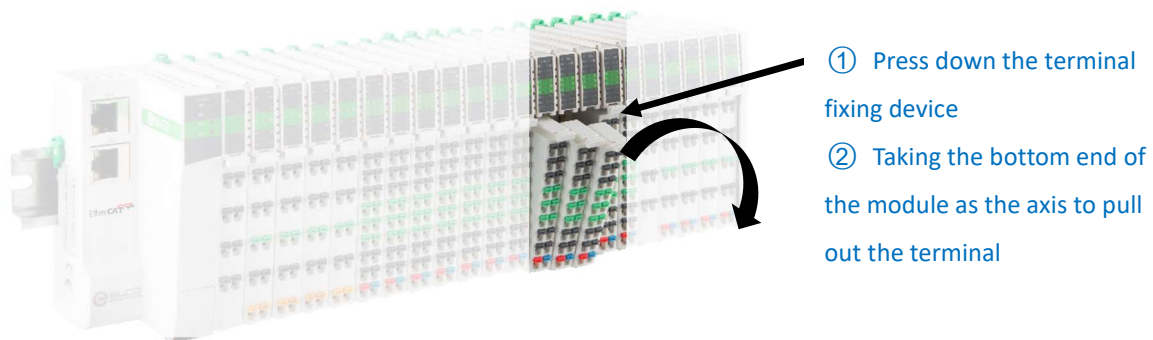

 **Warning!** 

The mechanical installation and disassembly of modules require qualified professional mechanical personnel to operate and pay attention to the correct wearing and use of labor protection equipment.

8. Electrical installation and wiring

8.1. Cable specification

8.1.1. Communication cable

CC-Link IE Field Basic bus communication uses shielded network cables for data transmission, without short circuits, misalignment, and poor contact; The length of the cable between devices cannot exceed 100m, as exceeding this length will cause signal attenuation and affect normal communication. The following specifications of communication cables are recommended:

Item	Specification
Cable type	Elastic crossover cable, S-FTP, category 5
Standards met	EIA/TIA568A,EN50173,ISO/IEC11801 EIA/TIA bulletin TSB,EIA/TIA SB40-A&TSB36
Conductor section	AWG26
Wire type	Twisted pair
Wire pair	4

Pre-wired connectors are better for communication and construction. Elco pre-wired connectors can provide customized cable material and cable length in accordance with communication technology requirements. The following Elco Ethernet connectors are available:

Model	Description
E16DA4002M020	RJ45-M12 double-ended pre-wired Ethernet connector, male straight, D-CODE, 4-pin, Cat5e, PVC, 2 M, fixed installation
E66D04002M020	RJ45-RJ45 double-ended pre-wired Ethernet connector, male straight-male straight, 4-pin, Cat5e, PVC, 2 M, fixed installation
E16DA4004M020	RJ45-M12 double-ended pre-wired Ethernet connector, male straight, D-CODE,4-pin, Cat5e, PVC, 2 M, suitable for drag chain
E66D04004M020	RJ45-RJ45 double-ended pre-wired Ethernet connector, male straight-male straight,4-pin, Cat5e, PUR,2 M, suitable for drag chain

i For more selection of Ethernet connectors, please refer to Elco's "Connectivity System Catalog".

8.1.2. Power and signal cables

The FX20 series adopts tool-free spring wiring terminals, and the wiring needs to be equipped with tube type cold pressing cable lugs. Please refer to the following figure for the stripping length and cable lug specifications:

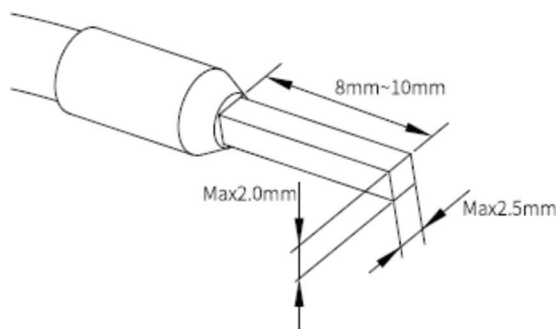

Standard cable crimper can be used for pressing the wire ear, as shown in the following figure:

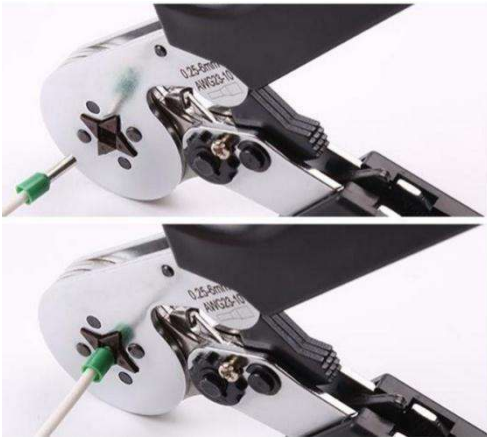

The wire connection does not need tools, and the wiring method is as follows:

- 1) Install the wire ear on the wire;
- 2) Insert the wire installed with the wire ear into the plug-in terminal to its most;
- 3) Pull the cable to ensure its fixed securely.

To release the wire:

- 1) Press the terminal spring button with your hand or a flat screwdriver
- 2) Pull out the wire and release the button.

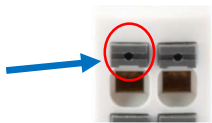

8.2. Modules wiring diagram

8.2.1. FX20 system power supply diagram

The FX20 series backplane 5VDC power supply is provided by the adapter, and IO power supply for function module needs to provide separately. Additionally, an auxiliary power supply module can provide a larger backplane power supply current. The power supply system diagram is as follows:

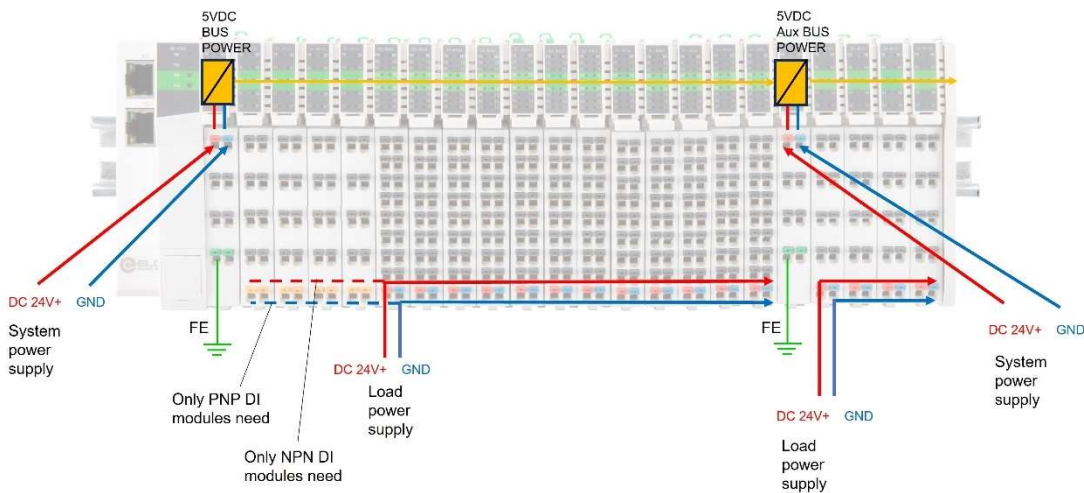

Warning!

- Be sure to disconnect all power connections before wiring!
- To ensure safety, must reliably connect the module grounding terminal to the ground!
- The wiring work must be operated by authorized electrical personnel to ensure safety!
- Using cables that do not meet the requirements will result in serious equipment damage or personal injury!

Please refer to this manual or the wiring diagram printed on the side of the module for wiring. Incorrect wiring will cause module damage or personal injury!

8.2.2. Bus adapters wiring diagram

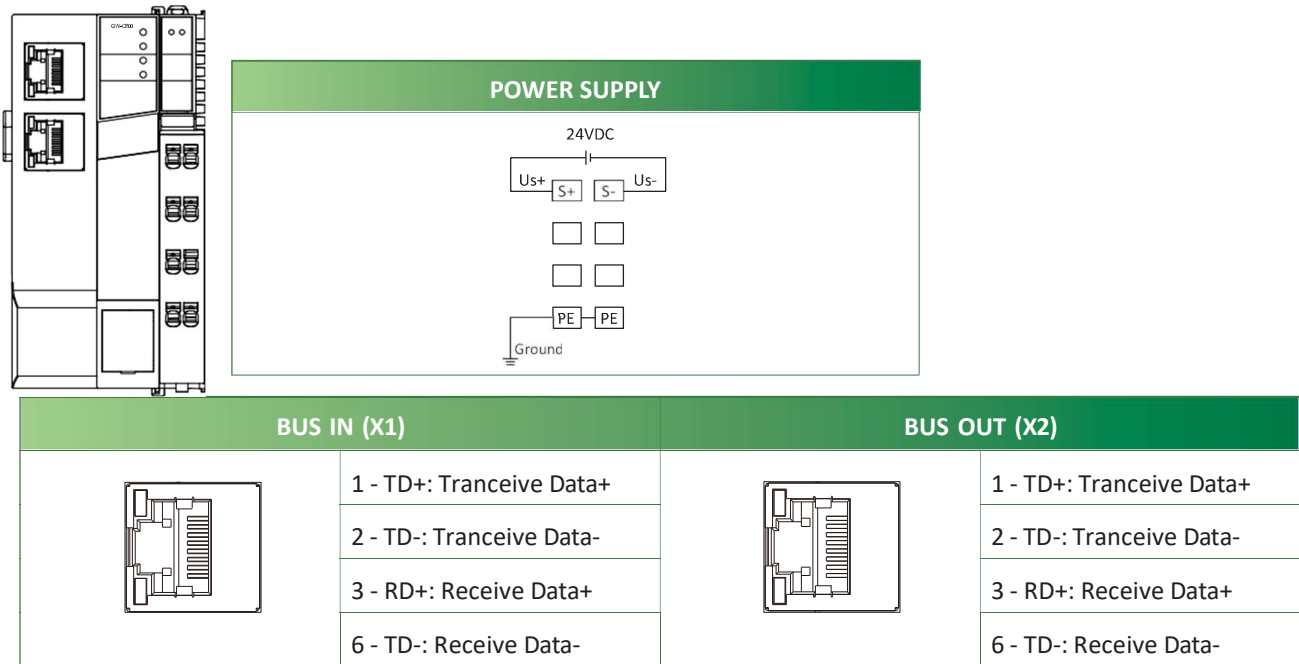

8.2.3. 8-channel DI module wiring diagram and I/O mapping

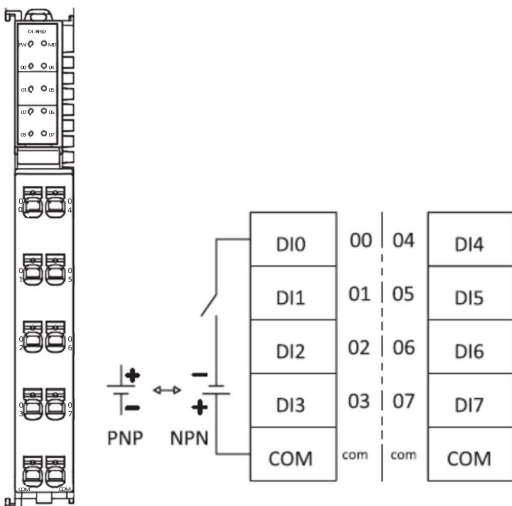

Model: FX20-DI-BF60

Input	Terminal No.	07	06	05	04	03	02	01	00
Byte 0	Address	I n.7	I n.6	I n.5	I n.4	I n.3	I n.2	I n.1	I n.0
	Byte 0	Bit 7	Bit 6	Bit 5	Bit 4	Bit 3	Bit 2	Bit 1	Bit 0

n: Starting byte of configuration

8.2.4. 8-channel DO PNP module wiring diagram and I/O mapping

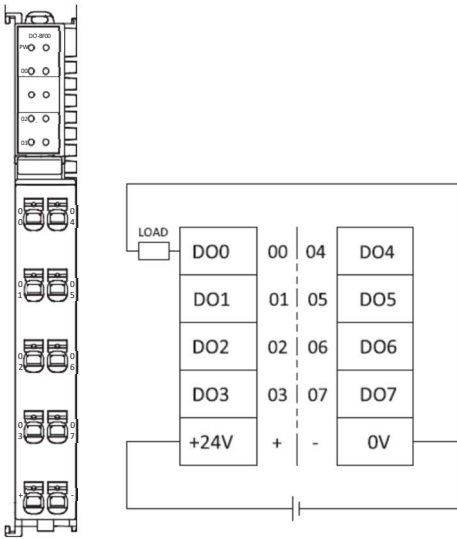

Model: FX20-DO-BF00									
Output	Terminal No.	07	06	05	04	03	02	01	00
Byte 0	Address	Q n.7	Q n.6	Q n.5	Q n.4	Q n.3	Q n.2	Q n.1	Q n.0
	Byte 0	Bit 7	Bit 6	Bit 5	Bit 4	Bit 3	Bit 2	Bit 1	Bit 0

n: Starting byte of configuration

8.2.5. 8-channel DO NPN module wiring diagram and I/O mapping

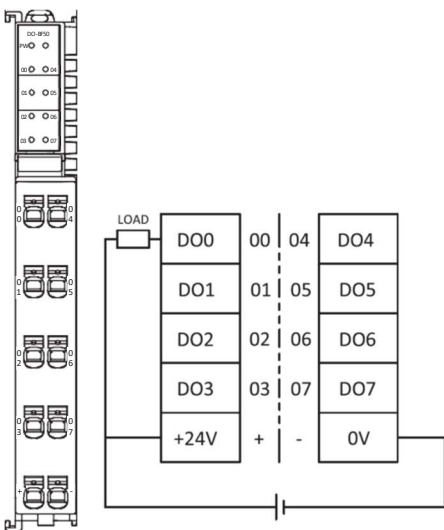

Model: FX20-DO-BF50									
Output	Terminal No.	07	06	05	04	03	02	01	00
Byte 0	Address	Q n.7	Q n.6	Q n.5	Q n.4	Q n.3	Q n.2	Q n.1	Q n.0
	Byte 0	Bit 7	Bit 6	Bit 5	Bit 4	Bit 3	Bit 2	Bit 1	Bit 0

n: Starting byte of configuration

8.2.6. 4-channel SSR (AC) output module wiring diagram I/O mapping

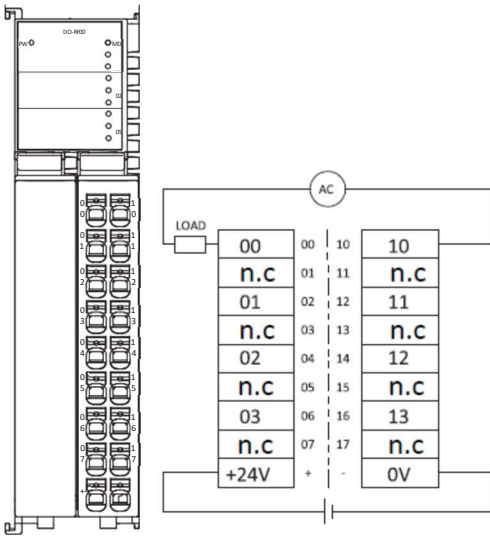

Model: FX20-DO-RD00

Output	Terminal No.	07	06	05	04	03	02	01	00
Byte 0	Address	-	-	-	-	Q n.3	Q n.2	Q n.1	Q n.0
	Byte 0	-	-	-	-	Bit 3	Bit 2	Bit 1	Bit 0
-	Terminal No.	17	16	15	14	13	12	11	10
-	Address	-	-	-	-	-	-	-	-

n: Starting byte of configuration

8.2.7. 8-channel relay output module wiring diagram and I/O mapping

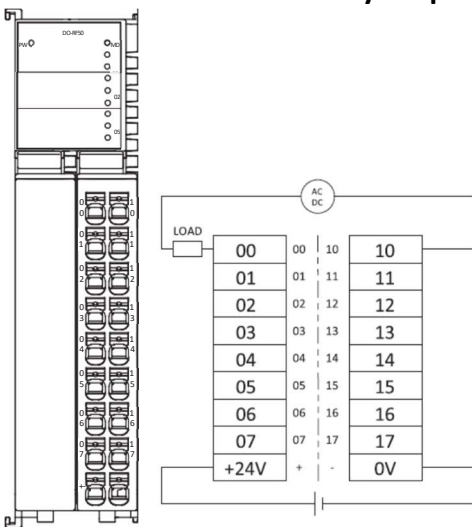

Model: FX20-DO-RF50

Output	Terminal No.	07	06	05	04	03	02	01	00
Byte 0	Address	Q n.7	Q n.6	Q n.5	Q n.4	Q n.3	Q n.2	Q n.1	Q n.0
	Byte 0	Bit 7	Bit 6	Bit 5	Bit 4	Bit 3	Bit 2	Bit 1	Bit 0
-	Terminal No.	17	16	15	14	13	12	11	10
-	Address	-	-	-	-	-	-	-	-

n: Starting byte of configuration

8.2.8. 16-channel DI module wiring diagram and I/O mapping

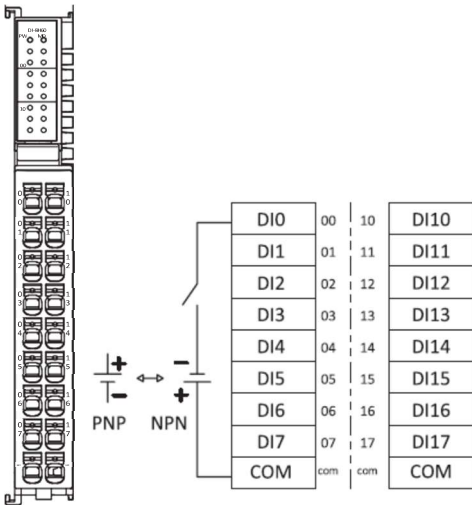

Model: FX20-DI-BH60

Input	Terminal No.	07	06	05	04	03	02	01	00
Byte 0	Address	I n.7	I n.6	I n.5	I n.4	I n.3	I n.2	I n.1	I n.0
	Byte 0	Bit 7	Bit 6	Bit 5	Bit 4	Bit 3	Bit 2	Bit 1	Bit 0
Input	Terminal No.	17	16	15	14	13	12	11	10
Byte 1	Address	I(n+1).7	I(n+1).6	I(n+1).5	I(n+1).4	I(n+1).3	I(n+1).2	I(n+1).1	I(n+1).0
	Byte 1	Bit 7	Bit 6	Bit 5	Bit 4	Bit 3	Bit 2	Bit 1	Bit 0

n: Starting byte of configuration

8.2.9. 16-channel DO PNP module wiring diagram and I/O mapping

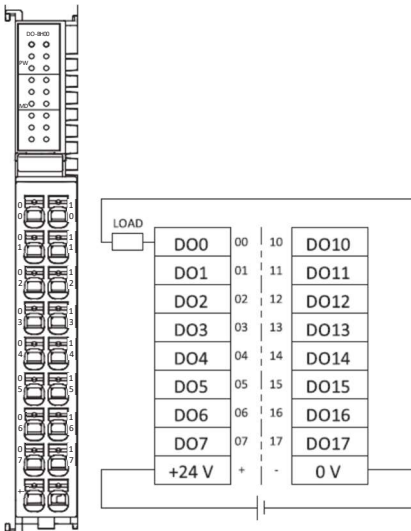

Model: FX20-DO-BH00

Output	Terminal No.	07	06	05	04	03	02	01	00
Byte 0	Address	Q n.7	Q n.6	Q n.5	Q n.4	Q n.3	Q n.2	Q n.1	Q n.0
	Byte 0	Bit 7	Bit 6	Bit 5	Bit 4	Bit 3	Bit 2	Bit 1	Bit 0
Output	Terminal No.	17	16	15	14	13	12	11	10

Byte 1	Address	Q(n+1).7	Q(n+1).6	Q (n+1).5	Q(n+1).4	Q(n+1).3	Q (n+1).2	Q (n+1).1	Q (n+1).0
	Byte 1	Bit 7	Bit 6	Bit 5	Bit 4	Bit 3	Bit 2	Bit 1	Bit 0

n: Starting byte of configuration

8.2.10. 16-channel DO NPN module wiring diagram and I/O mapping

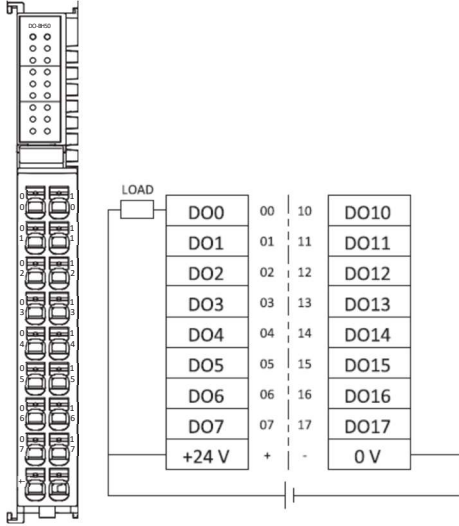

Model: FX20-DO-BH50

Output t	Terminal No.	07	06	05	04	03	02	01	00
Byte 0	Address	Q n.7	Q n.6	Q n.5	Q n.4	Q n.3	Q n.2	Q n.1	Q n.0
	Byte 0	Bit 7	Bit 6	Bit 5	Bit 4	Bit 3	Bit 2	Bit 1	Bit 0
Output t	Terminal No.	17	16	15	14	13	12	11	10
Byte 1	Address	Q(n+1).7	Q(n+1).6	Q (n+1).5	Q(n+1).4	Q(n+1).3	Q (n+1).2	Q (n+1).1	Q (n+1).0
	Byte 1	Bit 7	Bit 6	Bit 5	Bit 4	Bit 3	Bit 2	Bit 1	Bit 0

n: Starting byte of configuration

8.2.11. 32-channel DI module wiring diagram and I/O mapping

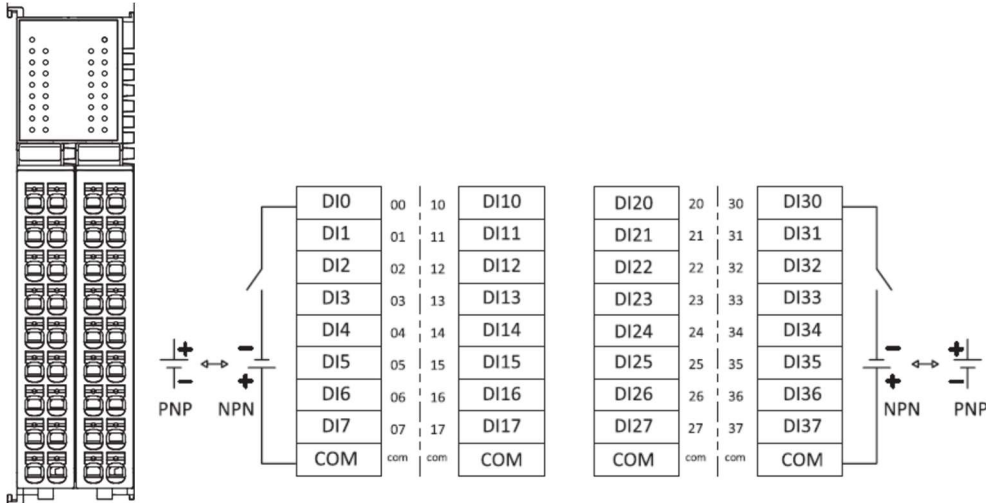

Model: FX20-DI-BL60

Input	Terminal No.	07	06	05	04	03	02	01	00
Byte 0	Address	I n.7	I n.6	I n.5	I n.4	I n.3	I n.2	I n.1	I n.0
	Byte 0	Bit 7	Bit 6	Bit 5	Bit 4	Bit 3	Bit 2	Bit 1	Bit 0
Input	Terminal No.	17	16	15	14	13	12	11	10
Byte 1	Address	I(n+1).7	I(n+1).6	I (n+1).5	I(n+1).4	I(n+1).3	I (n+1).2	I (n+1).1	I (n+1).0
	Byte 1	Bit 7	Bit 6	Bit 5	Bit 4	Bit 3	Bit 2	Bit 1	Bit 0
Input	Terminal No.	27	26	25	24	23	22	21	20
Byte 2	Address	I(n+2).7	I(n+2).6	I (n+2).5	I(n+2).4	I(n+2).3	I (n+2).2	I (n+2).1	I (n+2).0
	Byte 2	Bit 7	Bit 6	Bit 5	Bit 4	Bit 3	Bit 2	Bit 1	Bit 0
Input	Terminal No.	37	36	35	34	33	32	31	30
Byte 3	Address	I(n+3).7	I(n+3).6	I (n+3).5	I(n+3).4	I(n+3).3	I (n+3).2	I (n+3).1	I (n+3).0
	Byte 3	Bit 7	Bit 6	Bit 5	Bit 4	Bit 3	Bit 2	Bit 1	Bit 0

n: Starting byte of configuration

8.2.12. 32-channel DO PNP module wiring diagram and I/O mapping

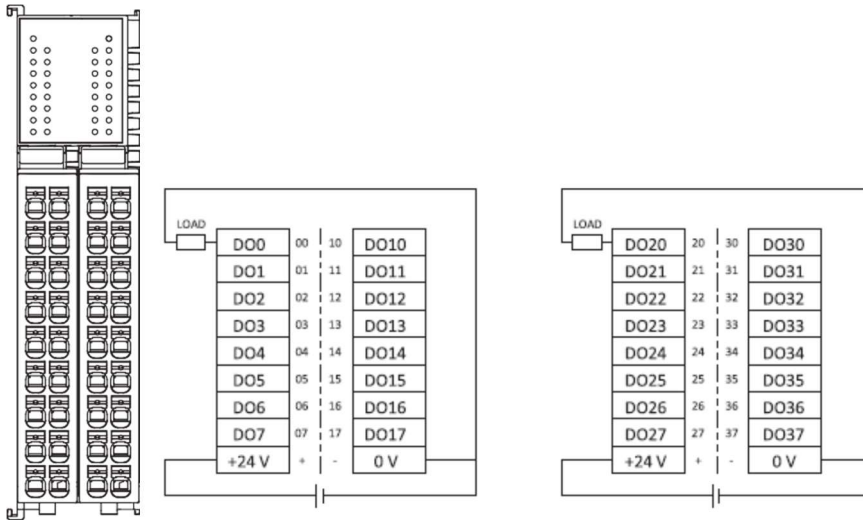

Model: FX20-DO-BL00

Output	Terminal No.	07	06	05	04	03	02	01	00
Byte 0	Address	Q n.7	Q n.6	Q n.5	Q n.4	Q n.3	Q n.2	Q n.1	Q n.0
	Byte 0	Bit 7	Bit 6	Bit 5	Bit 4	Bit 3	Bit 2	Bit 1	Bit 0
Output	Terminal No.	17	16	15	14	13	12	11	10
Byte 1	Address	Q(n+1).7	Q(n+1).6	Q (n+1).5	Q(n+1).4	Q(n+1).3	Q (n+1).2	Q (n+1).1	Q (n+1).0
	Byte 1	Bit 7	Bit 6	Bit 5	Bit 4	Bit 3	Bit 2	Bit 1	Bit 0
Output	Terminal No.	27	26	25	24	23	22	21	20
Byte 2	Address	Q(n+2).7	Q(n+2).6	Q (n+2).5	Q(n+2).4	Q(n+2).3	Q (n+2).2	Q (n+2).1	Q (n+2).0
	Byte 2	Bit 7	Bit 6	Bit 5	Bit 4	Bit 3	Bit 2	Bit 1	Bit 0
Output	Terminal No.	37	36	35	34	33	32	31	30
Byte 3	Address	Q(n+3).7	Q(n+3).6	Q (n+3).5	Q(n+3).4	Q(n+3).3	Q (n+3).2	Q (n+3).1	Q (n+3).0
	Byte 3	Bit 7	Bit 6	Bit 5	Bit 4	Bit 3	Bit 2	Bit 1	Bit 0

n: Starting byte of configuration

8.2.13. 32-channel DO NPN module wiring diagram and I/O mapping

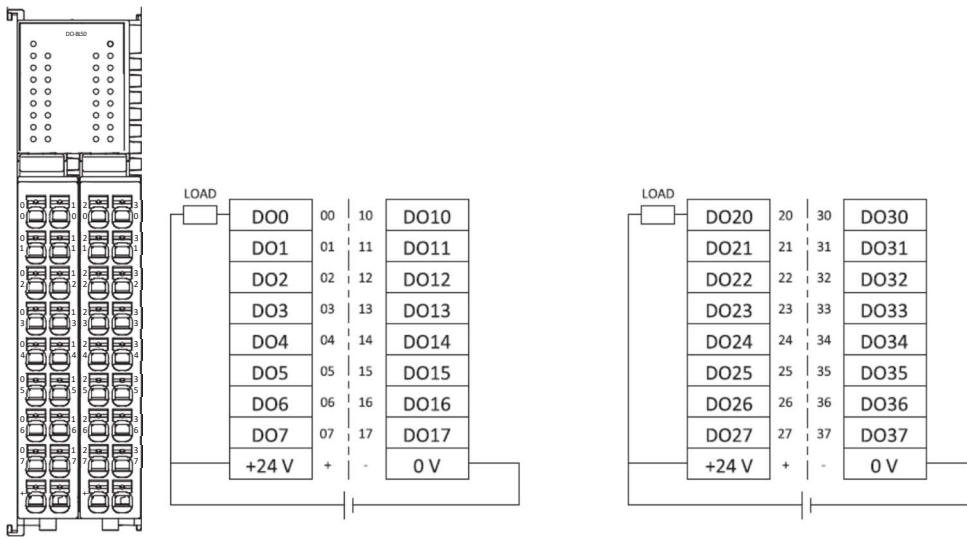

Model: FX20-DO-BL50

Output	Terminal No.	07	06	05	04	03	02	01	00
Byte 0	Address	Q n.7	Q n.6	Q n.5	Q n.4	Q n.3	Q n.2	Q n.1	Q n.0
	Byte 0	Bit 7	Bit 6	Bit 5	Bit 4	Bit 3	Bit 2	Bit 1	Bit 0
Output	Terminal No.	17	16	15	14	13	12	11	10
Byte 1	Address	Q(n+1).7	Q(n+1).6	Q (n+1).5	Q(n+1).4	Q(n+1).3	Q (n+1).2	Q (n+1).1	Q (n+1).0
	Byte 1	Bit 7	Bit 6	Bit 5	Bit 4	Bit 3	Bit 2	Bit 1	Bit 0
Output	Terminal No.	27	26	25	24	23	22	21	20
Byte 2	Address	Q(n+2).7	Q(n+2).6	Q (n+2).5	Q(n+2).4	Q(n+2).3	Q (n+2).2	Q (n+2).1	Q (n+2).0
	Byte 2	Bit 7	Bit 6	Bit 5	Bit 4	Bit 3	Bit 2	Bit 1	Bit 0
Output	Terminal No.	37	36	35	34	33	32	31	30
Byte 3	Address	Q(n+3).7	Q(n+3).6	Q (n+3).5	Q(n+3).4	Q(n+3).3	Q (n+3).2	Q (n+3).1	Q (n+3).0
	Byte 3	Bit 7	Bit 6	Bit 5	Bit 4	Bit 3	Bit 2	Bit 1	Bit 0

n: Starting byte of configuration

8.2.14. 4-channel AI module wiring diagram and I/O mapping

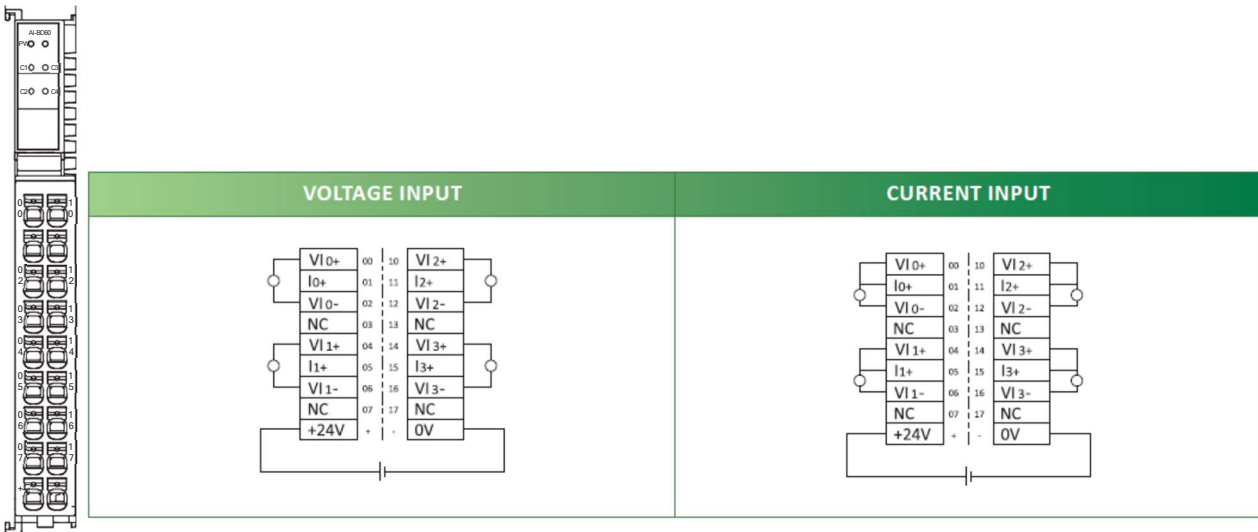

Model: FX20-AI-BD60								
Terminal No.	07	06	05	04	03	02	01	00
Address	IW n+2				IW n			
Channel	Channel 1				Channel 0			
Terminal No.	17	16	15	14	13	12	11	10
Address	IW n+6				IW n+4			
Channel	Channel 3				Channel 2			
n: Starting byte of configuration								

8.2.15. 4-channel AO module wiring diagram and I/O mapping

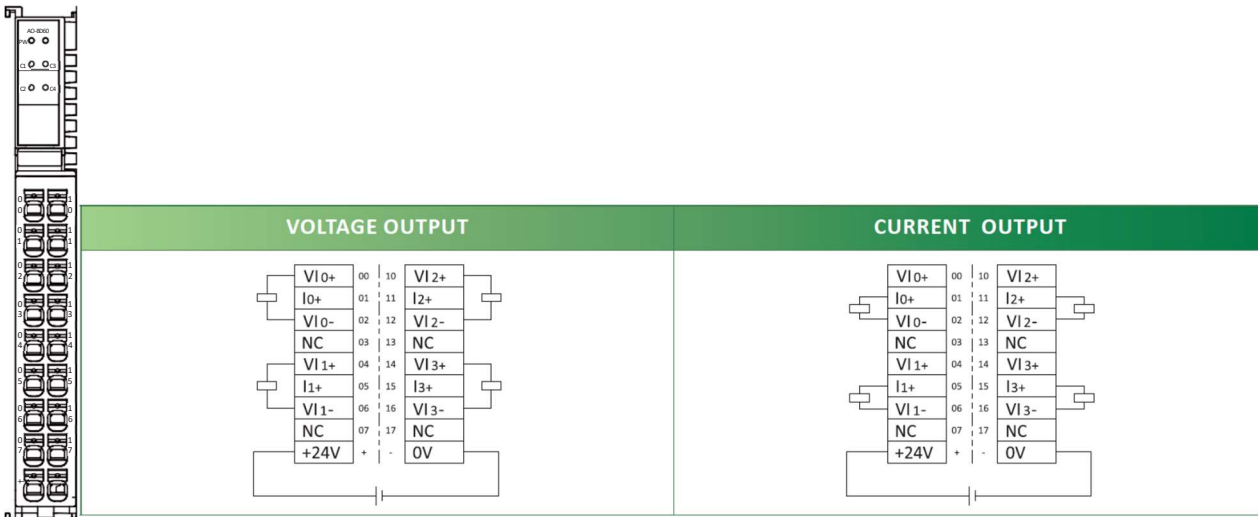

Model: FX20-AO-BD60

Terminal No.	07	06	05	04	03	02	01	00
Address	QW n+2				QW n			
Channel	Channel 1				Channel 0			
Terminal No.	17	16	15	14	13	12	11	10
Address	QW n+6				QW n+4			
Channel	Channel 3				Channel 2			

n: Starting byte of configuration

8.2.16. 8-channel AI module wiring diagram and I/O mapping

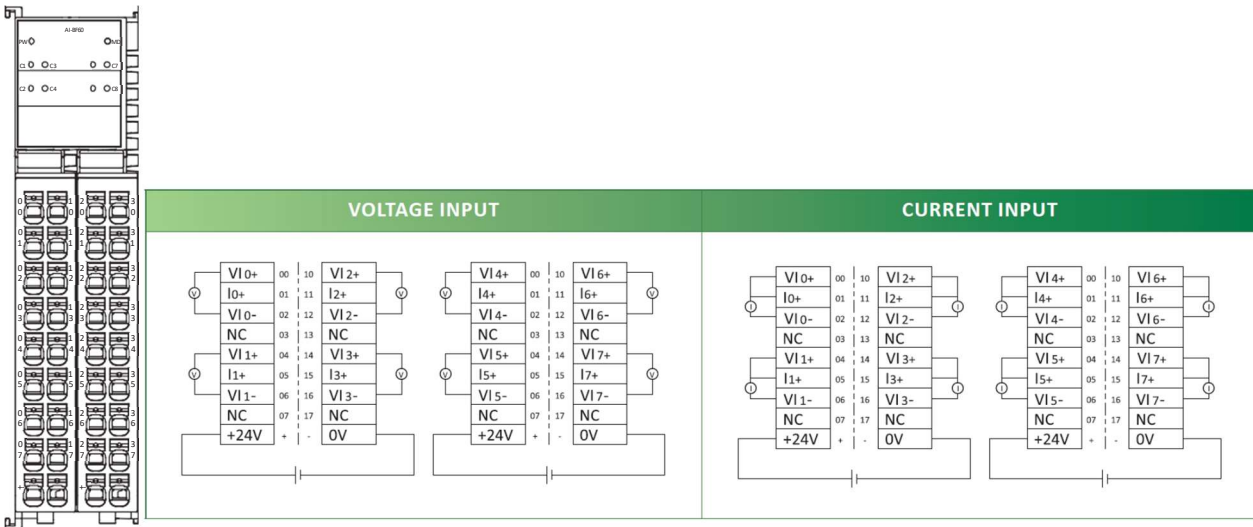

Model: FX20-AI-BF60

Terminal No.	07	06	05	04	03	02	01	00
Address	IW n+2				IW n			
Channel	Channel 1				Channel 0			
Terminal No.	17	16	15	14	13	12	11	10
Address	IW n+6				IW n+4			
Channel	Channel 3				Channel 2			
Terminal No.	27	26	25	24	23	22	21	20
Address	IW n+10				IW n+8			
Channel	Channel 5				Channel 4			
Terminal No.	37	36	35	34	33	32	31	30
Address	IW n+14				IW n+12			
Channel	Channel 7				Channel 6			

n: Starting byte of configuration

8.2.17. 8-channel AO module wiring diagram and I/O mapping

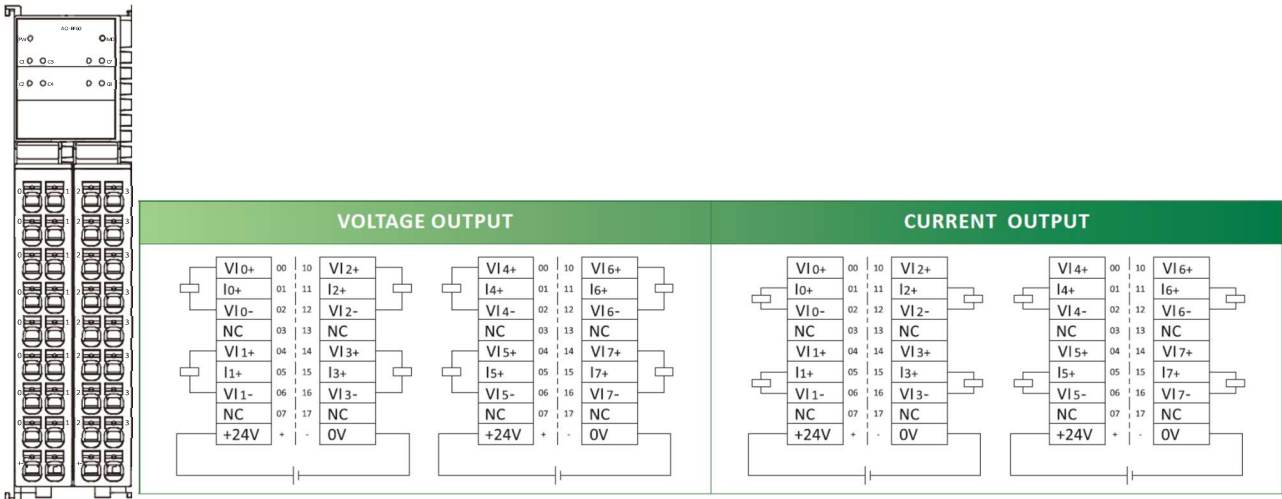

Model: FX20-AO-BF60								
Terminal No.	07	06	05	04	03	02	01	00
Address	QW n+2				QW n			
Channel	Channel 1				Channel 0			
Terminal No.	17	16	15	14	13	12	11	10
Address	QW n+6				QW n+4			
Channel	Channel 3				Channel 2			
Terminal No.	27	26	25	24	23	22	21	20
Address	QW n+10				QW n+8			
Channel	Channel 5				Channel 4			
Terminal No.	37	36	35	34	33	32	31	30
Address	QW n+14				QW n+12			
Channel	Channel 7				Channel 6			
n: Starting byte of configuration								

8.2.18. 4-channel RTD module wiring diagram and I/O mapping

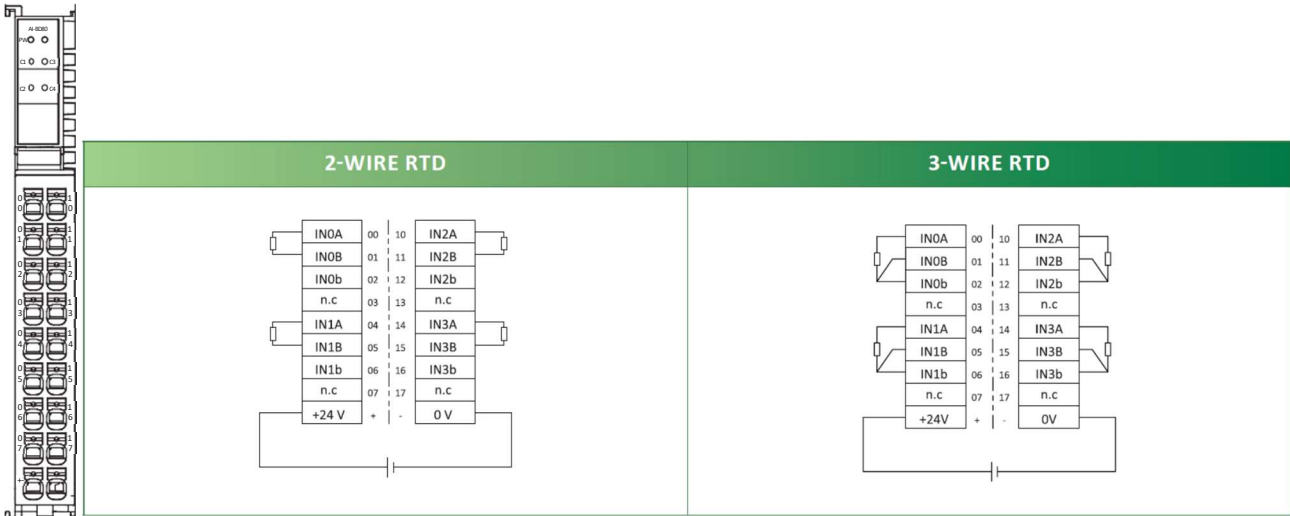

Model: FX20-AI-BD80

Terminal No.	07	06	05	04	03	02	01	00
Address	IW n+2				IW n			
Channel	Channel 1				Channel 0			
Terminal No.	17	16	15	14	13	12	11	10
Address	IW n+6				IW n+4			
Channel	Channel 3				Channel 2			

n: Starting byte of configuration

8.2.19. 4-channel TC module wiring diagram and I/O mapping

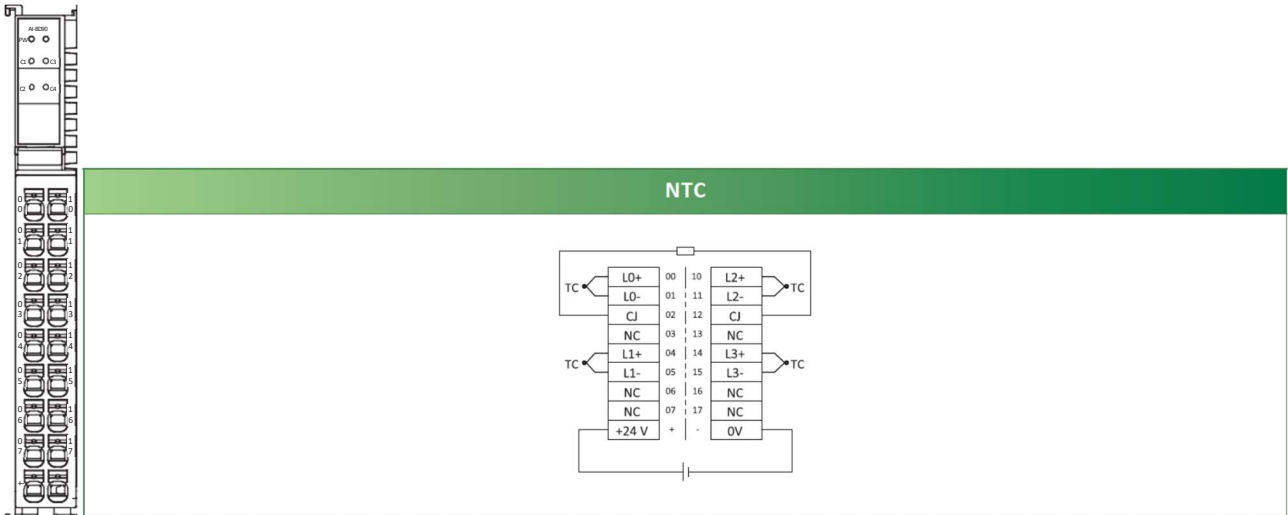

Model: FX20-AI-BD90

Terminal No.	07	06	05	04	03	02	01	00
Address	IW n+2				IW n			
Channel	Channel 1				Channel 0			
Terminal No.	17	16	15	14	13	12	11	10
Address	IW n+6				IW n+4			
Channel	Channel 3				Channel 2			

n: Starting byte of configuration

8.2.20. Auxiliary power module wiring diagram

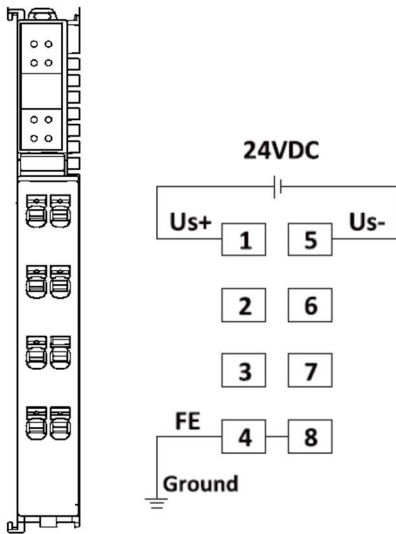

Warning!

- Module wiring diagrams are printed on the side of the module for easy reference during wiring and debugging.
- Only electrical technicians can carry out wiring and related operations.

9. Configuration and test

9.1. FX20 I/O Mapping in CC-Link IE Field Basic

9.1.1. Input/output allocation

Link Side					CPU Side				
Device Name	Points	Start	End		Target	Device Name	Points	Start	End
RX	64	00000	0003F	↔	Specify Devi	X	64	100	177
RY	64	00000	0003F	↔	Specify Devi	Y	64	100	177
RWr	32	00000	0001F	↔	Specify Devi	D	32	200	231
RWw	32	00000	0001F	↔	Specify Devi	D	32	400	431

9.1.2. Register allocation

No.	Definition	Slot	Data type	Input	Output	Description
1	I/O modules fault status register	None	Word	RWr0	RWw0 (Reserved)	Slot1-Slot16 I/O modules status, 0-Normal, 1-Fault
			Word	RWr1	RWw1 (Reserved)	Slot17-Slot32 I/O modules status, 0-Normal,1-Fault
	Word		RWr2	RWw2 (Reserved)	Slot1-Slot16 I/O modules connection status 0-Normal,1-Fault	
	Word		RWr3	RWw3 (Reserved)	Slot17-Slot32 I/O modules connection status 0-Normal,1-Fault	
2	Slot1_AD1	1	Word	RWr4	RWw4	Data from channel 1 of slot 1 module
3	Slot1_AD2	1	Word	RWr5	RWw5	Data from channel 2 of slot 1 module
4	Slot1_AD3	1	Word	RWr6	RWw6	Data from channel 3 of slot 1 module
5	Slot1_AD4	1	Word	RWr7	RWw7	Data from channel 4 of slot 1 module
...
62	Slot16_AD1	16	Word	RWr64	RWw64	Data from channel 1 of slot 16 module
63	Slot16_AD2	16	Word	RWr65	RWw65	Data from channel 2 of slot 16 module
64	Slot16_AD3	16	Word	RWr66	RWw66	Data from channel 3 of slot 16 module
65	Slot16_AD4	16	Word	RWr67	RWw67	Data from channel 4 of slot 16 module

Attention: The remote registers RWr and RWw store I/O process data of non-digital modules of FX20 slave stations (such as analog input/output modules, temperature measurement and other functional modules), and their slot numbers are only sorted according to non-digital modules. If digital modules are interspersed in the middle slot, the slot numbers ignore the digital modules.

9.2. CC-Link IE Field Basic profile

The CC-Link IE Field BASIC profile (CSPP file) is an important document used to describe device parameters and build networks. It is mainly used to describe specific parameters and network configurations of the device during the configuration process. The CSPP file needs to be imported in order to easily integrate FX20 series I/O modules into Mitsubishi PLC systems through the CC-Link IE Field BASIC bus.

9.2.1. CSPP file registration

9.2.1.1. Open MELSOFT GX Works3 software, select "Tool" ->"Profile Management" ->"Register..." in the

menu bar, and click to open a new window.

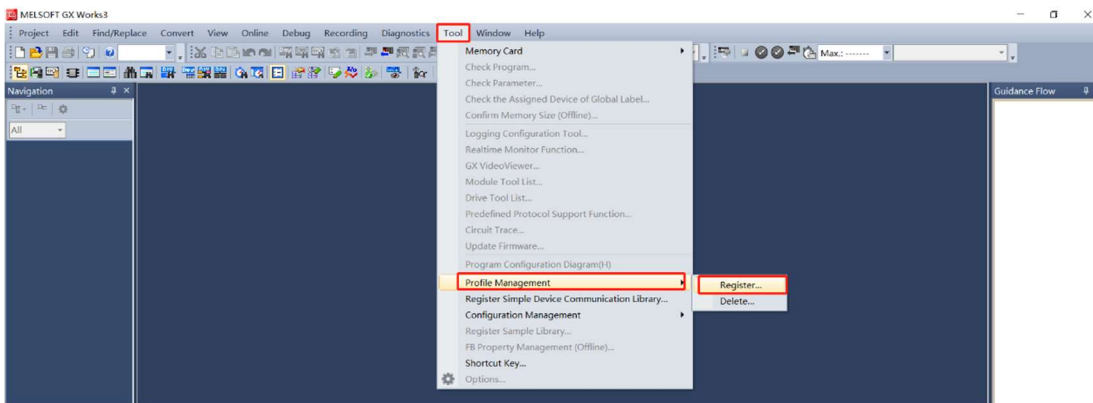

9.2.1.2. Select the version of the CSPP file to import and click “Register”, The CSPP file can be registered and completed.

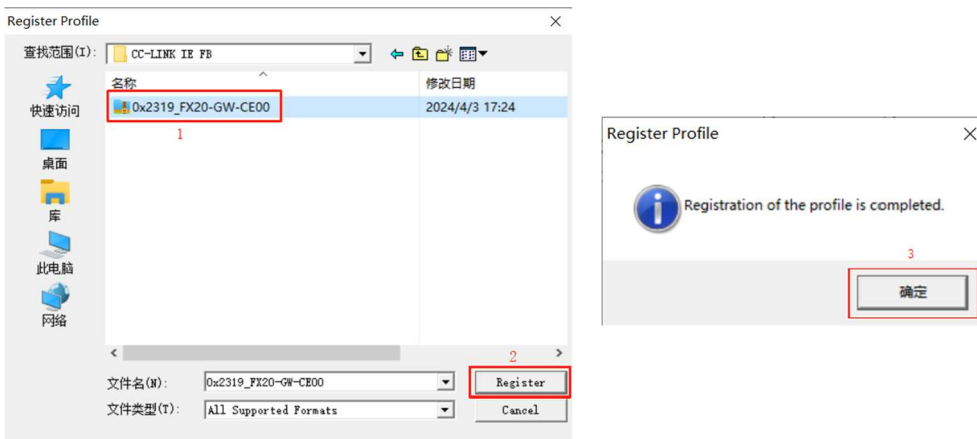

Note: Do not decompress this file.

9.3. FX20 configuration and test in Mitsubishi GX Works3

This section provides users with a comprehensive understanding of the actual use of FX20 series I/O modules through a configuration process. This example uses the FX20 from Elco as the CC-Link IE Field Basic slave station, and connects to Mitsubishi FX5CPU. By default, all power supply and bus connections have been completed.

The FX20 series modular I/O system uses the following products as configuration examples:

Model	Description	Quantity
FX20-GW-CE00	CC-Link IE Field Basic adapter	1
FX20-DI-BF60	8 digital PNP/NPN input module	1
FX20-DO-BF50	8 digital NPN output module	1
FX20-AI-BD60	4 analog mixed input modules	1
FX20-AO-BD60	4 analog mixed output modules	1

9.3.1. Turn off enhanced security mode

The user authentication function of FX5U may have an impact on third-party devices in the network. To turn off user authentication mode in GX Works3 software, you can select " Switch Enhanced Security mode... " from the "View" menu without opening the project, select 'Disable' and click 'OK' to exit.

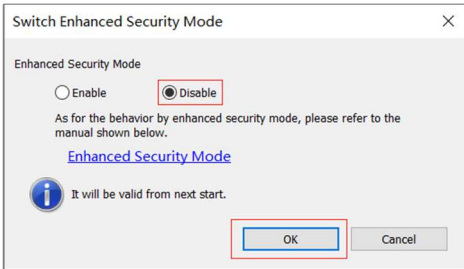
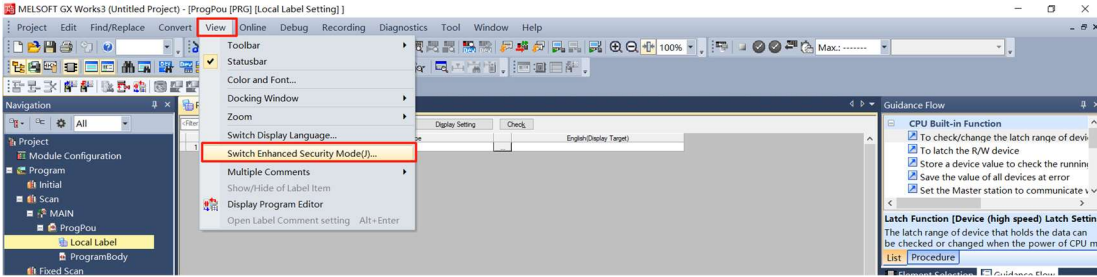

9.3.2. Configuration steps in GX Work3

9.3.2.1. Create a new GX Works3 project.

Click "Project>New...", select the PLC series "FX5CPU" and model "FX5U" in the pop-up dialog box, choose the programming language according to your habits, and then click "OK" to create the project.

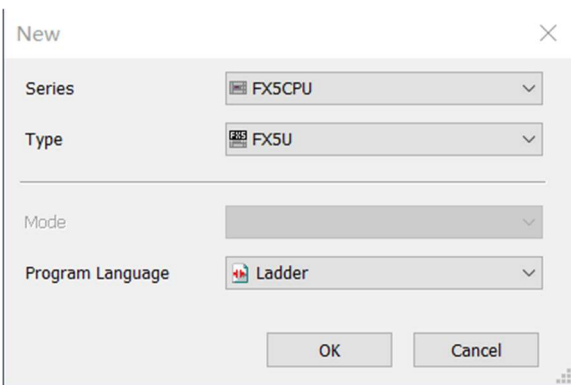
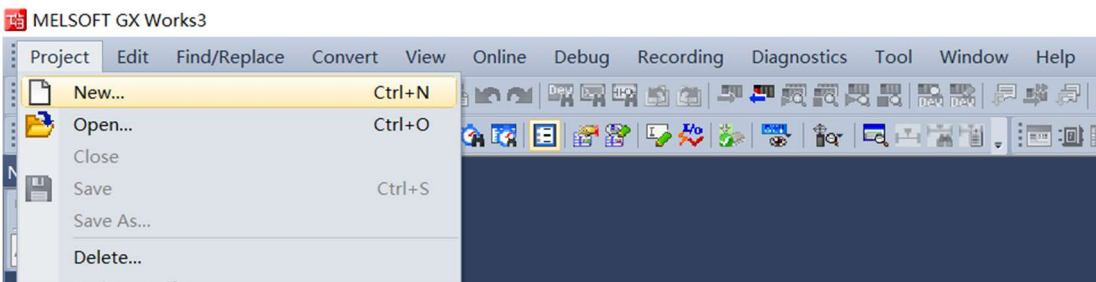

9.3.2.1. After entering the interface, select the "Navigation" project tree on the left side, and then choose "Parameter>Module Parameter>Ethernet Port" Double click to enter the network settings interface.

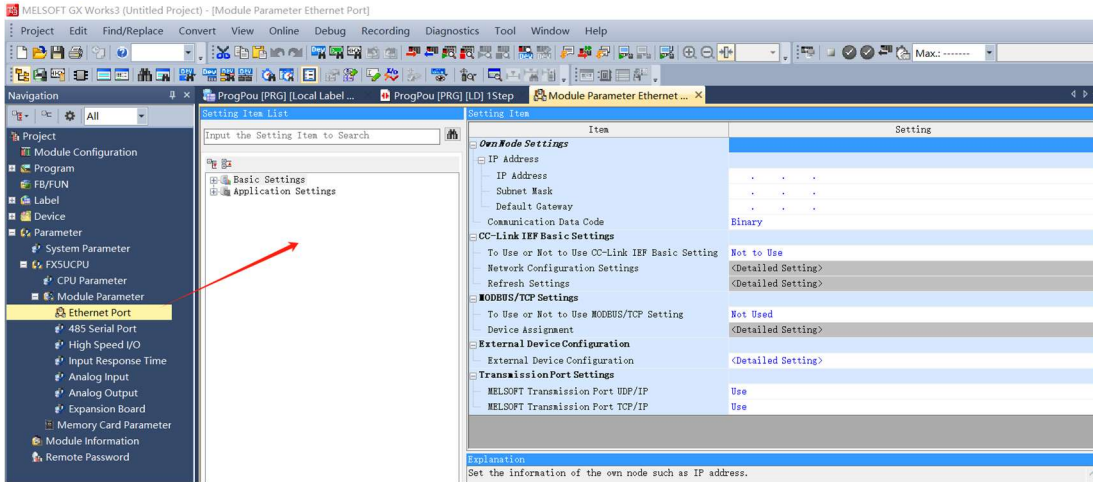

9.3.2.2. In the newly opened window, set the IP address of the PLC to "192.168.3.250" and the subnet mask to "255.255.255.0". Users can also set according to their own needs, please note that the PLC and module need to be on the same IP network segment.

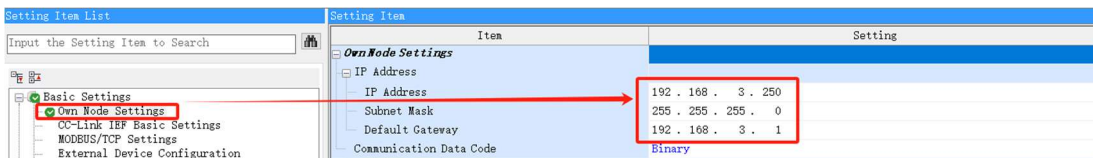

9.3.2.3. Enable CC-Link IE Field Basic network settings, click on the "To Use or Not to use CIB Setting" option, and select "Use" to enable network settings.



9.3.2.4. Perform CC-Link IE Field Basic network configurations.

a) Click the button on the right side of "Network Configuration Settings" or double-click the text to open the "Detailed Setting" option.

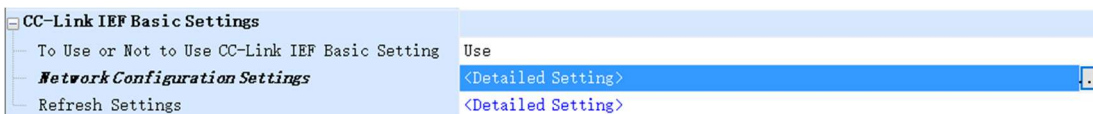

b) In the newly opened "CC-Link IEF Basic Configuration" window, click the "Detect Now" button, click "Yes" to automatically scan the FX20 connected to the PLC.

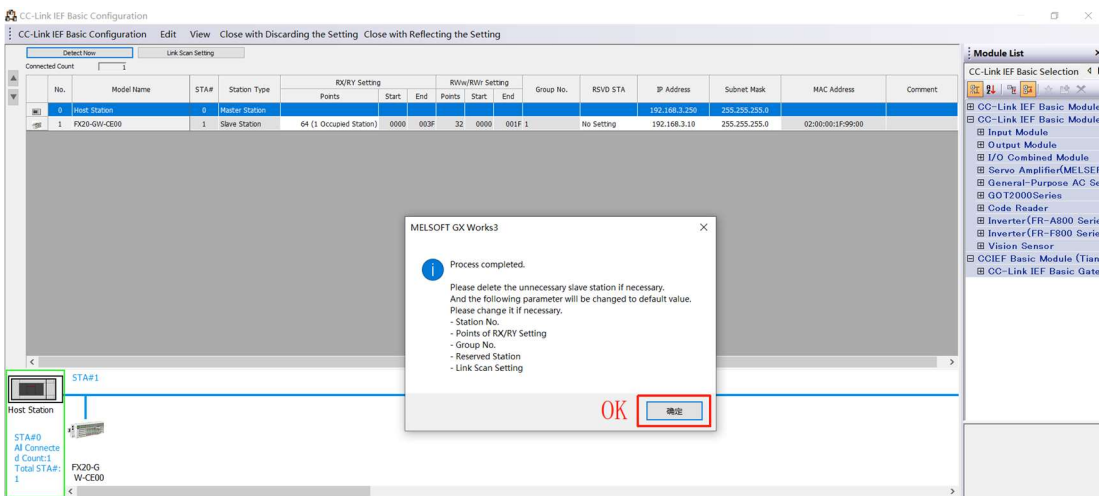
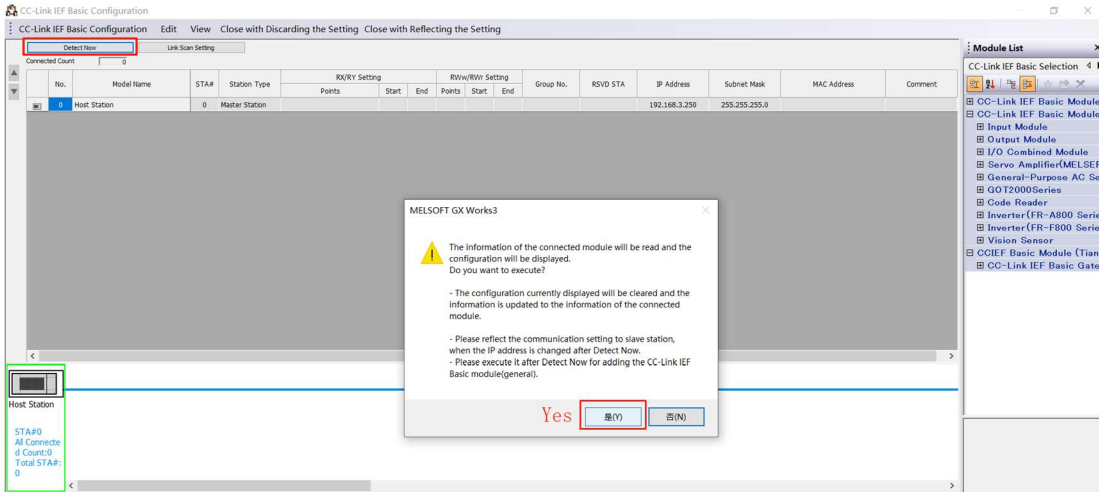

- c) Scan completed, click the 'OK' button. Here you can see the IP address and MAC address, as shown in the figure. The default IP address for FX20 at the factory is 192.168.3.10, if you need to modify the IP address, you can enter the IP address to be modified in the IP address bar. For example, change it to 192.168.3.5, right-click on the module model, select "Online>Communication Setting Reflection of Slave Station", click "yes", and the IP address will be modified.

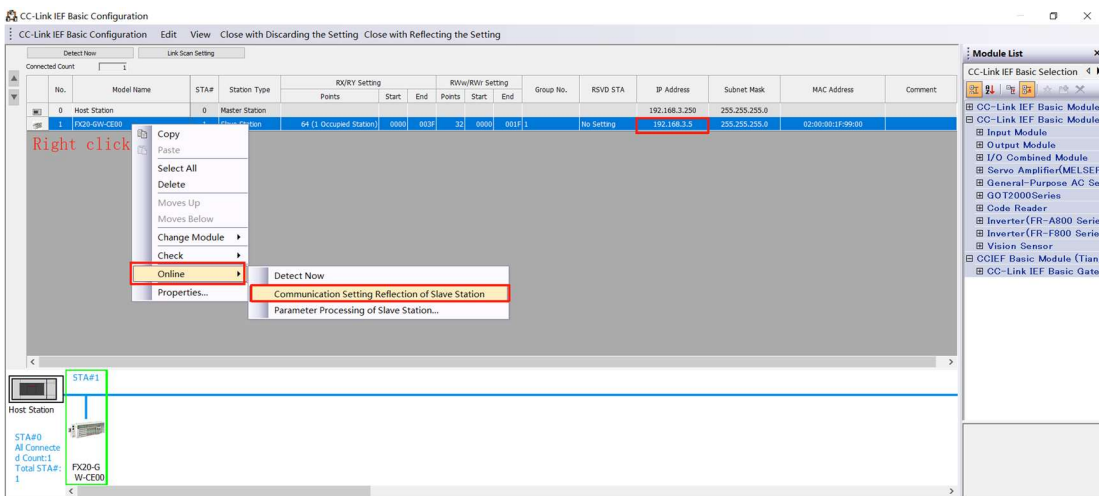

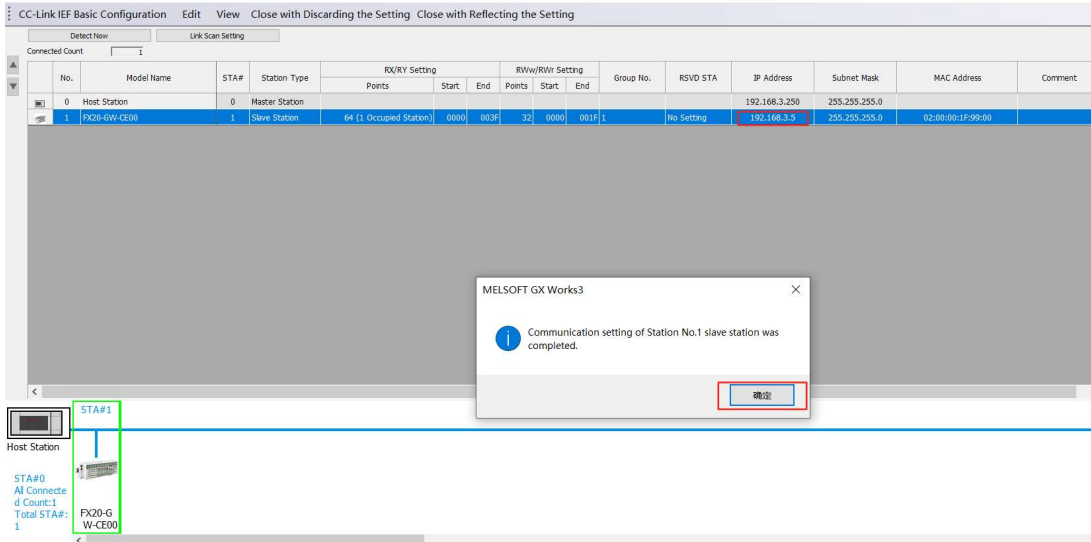

- d) Right click on the FX20 and select "Parameter Processing of Slave Station..." under the "Online" option to enter the module parameter settings page. We first read the parameters of each module in FX20, select "Parameter read" in Method selection, check all parameters "Select All", click "Execute", wait for a few seconds, and all FX20 module parameters will be automatically read into the "Read value" column.

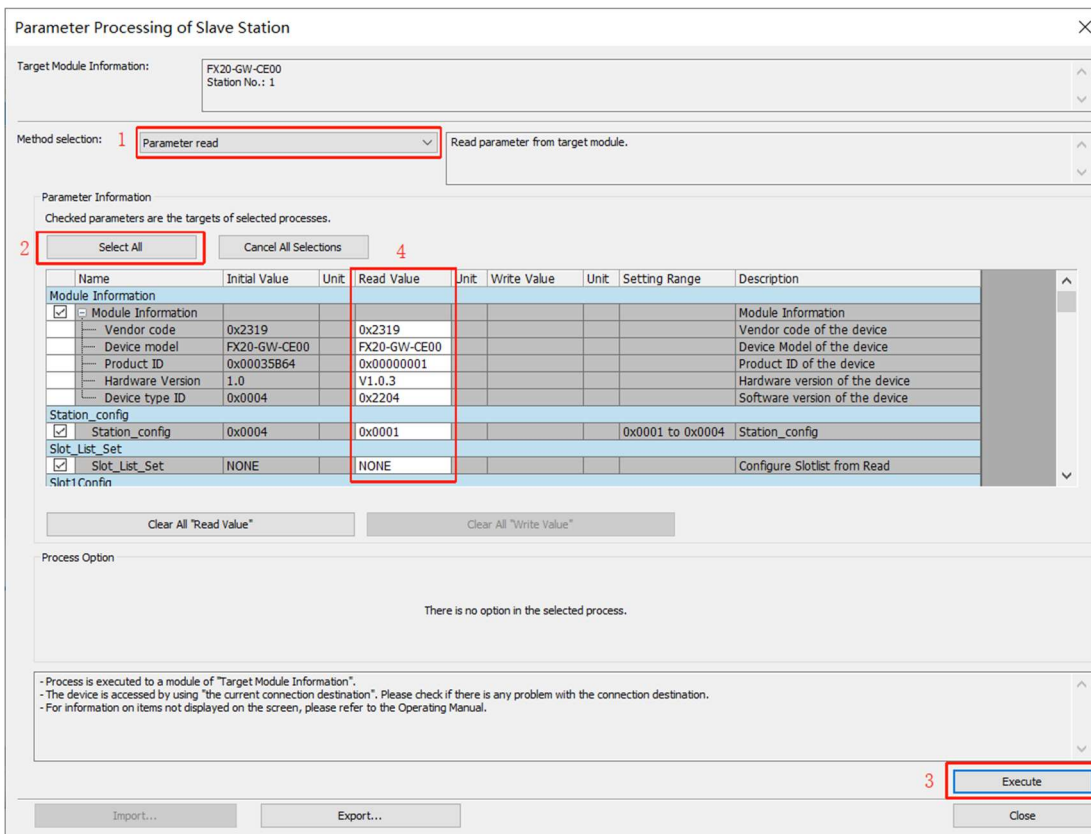

- e) I/O modules parameters configuration
 Change the Method selection to "Parameter write", modify the channel parameters of each slot module as needed and refer to the corresponding description of each parameter, such as filtering settings for digital input modules, range selection for analog quantities, etc. It should be noted that before writing the parameters of each slot module, the model of that module needs to be selected first. After setting

the parameters, click "Execute" to write the parameters.

Note: Because FX20 allows a max 32 slots for parameter configuration, when writing parameters, only select the slots that need to be set, and ensure that each parameter cannot be empty.

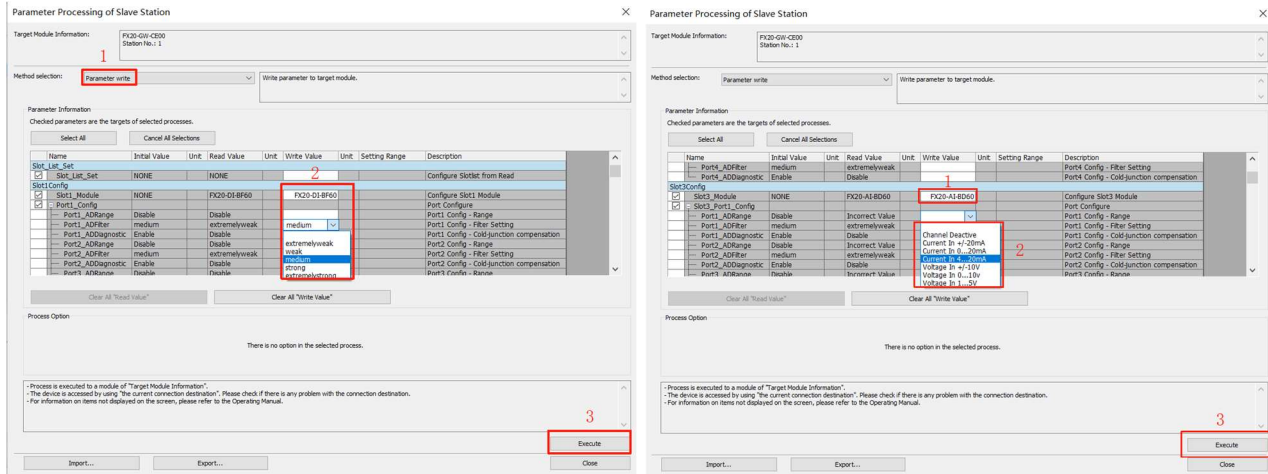

f) After completing all module settings, click "Close with Reflecting the Setting" to exit the settings interface.

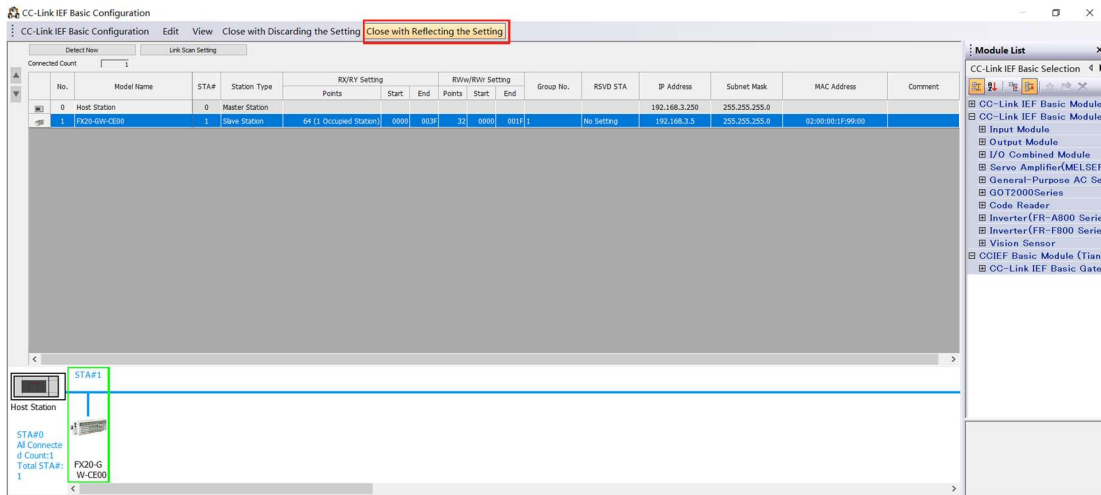

9.3.2.5. Set up CC-Link IE Field Basic network refresh and mapping

- i. Click the button to the right of "Refresh Settings" or double-click the text to open the "Detailed Setting" option.



- ii. In the newly opened "Setting Item" interface, assign mapping addresses for RX, RY, RWr, and RWw in the PLC as needed, and then click the "Apply" button as shown in the figure.

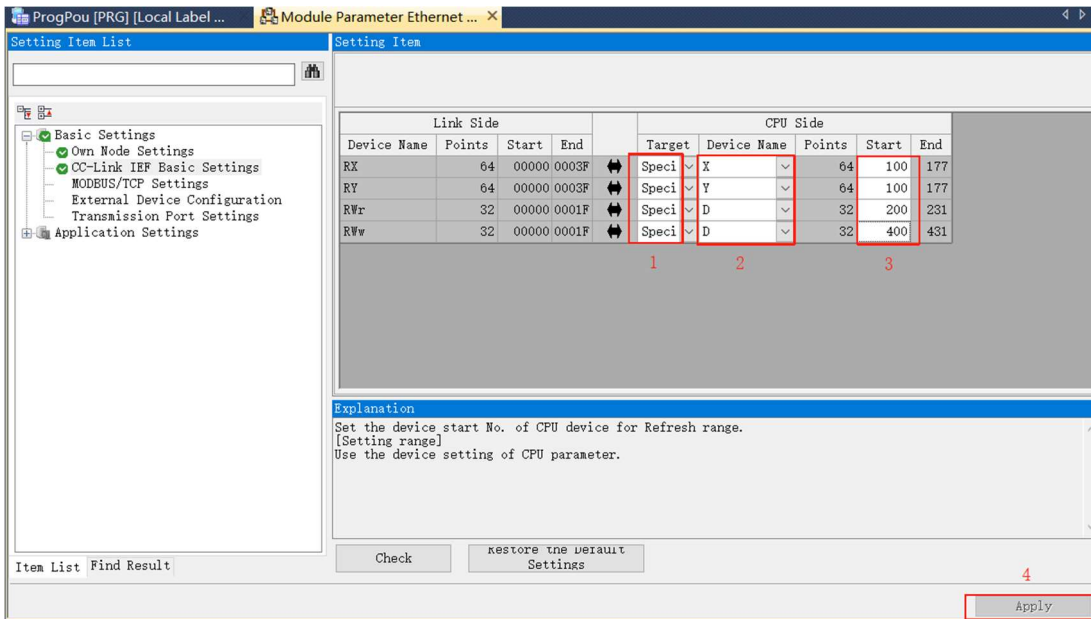

9.3.2.6. FX20 configuration completed, download the configuration to PLC, select "Online>Write to PLC..." to open the download window, choose "Select All" and click the "Execute" button to execute the download.

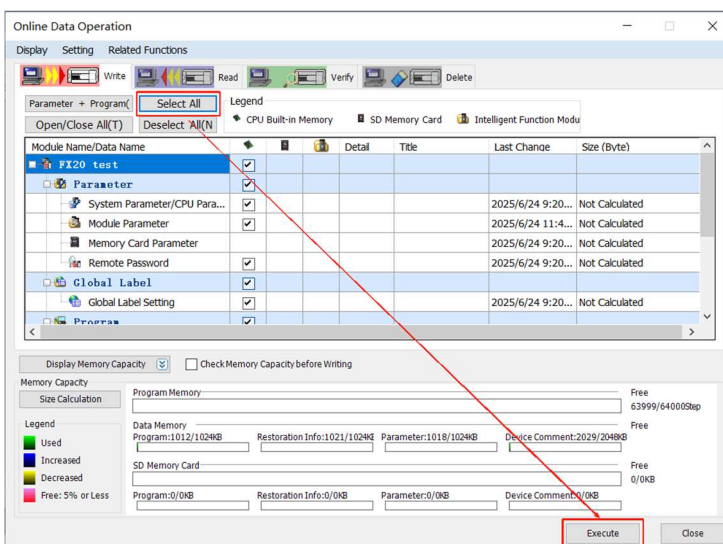
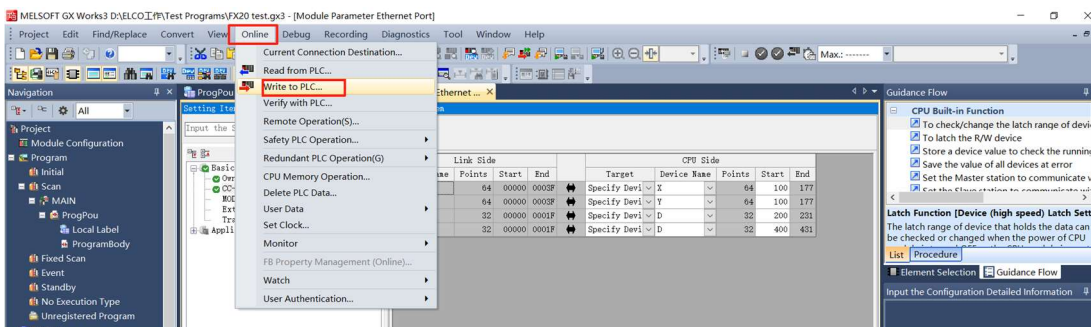

9.3.2.7. After the configuration download is successful, it is necessary to restart the PLC power supply for reset operation. At this time, the FX20 adapter BF indicator light is green and constantly on, indicating that communication with the PLC has been correctly established and the configuration is successful.

9.3.2.8. Input/output test

- i. Click on "online>Monitor>Device Monitor/Buffer Memory Batch Monitor " to open the monitoring interface.

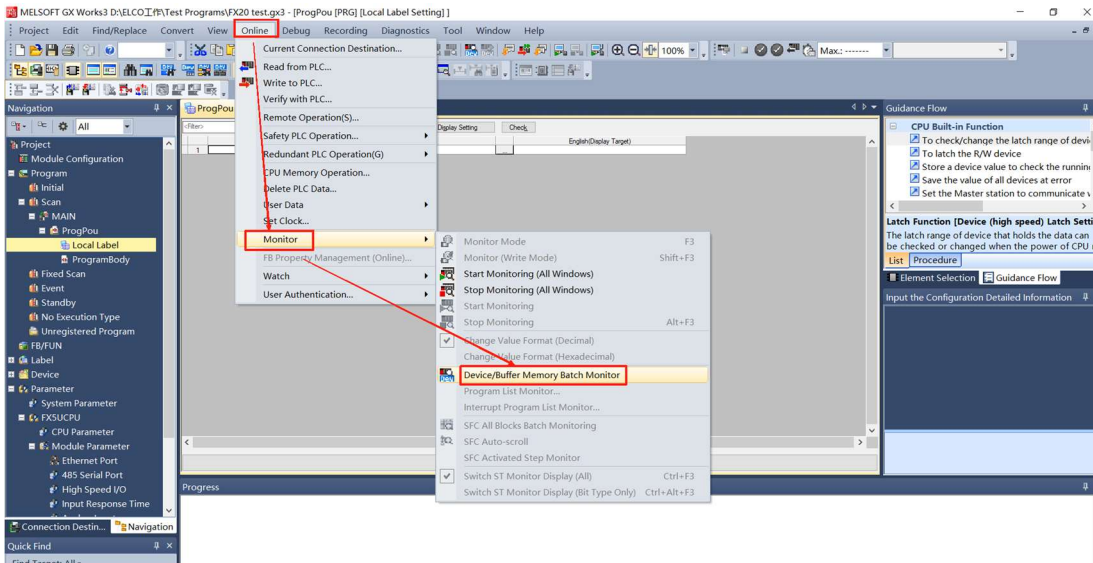

- ii. We connect the corresponding channel of the FX20 digital output module to the input module FX20-DI-BF60 through wires. Similarly, connect the channels corresponding to the analog output and analog input modules.
- iii. According to the I/O mapping, select the starting address Y100 of the output module and click "Start Monitoring". Double clicks on channels 0-7 or right-click on "Modify value" to force output, and the output channel of FX20-DO-BF50 indicator lights will be turned on.

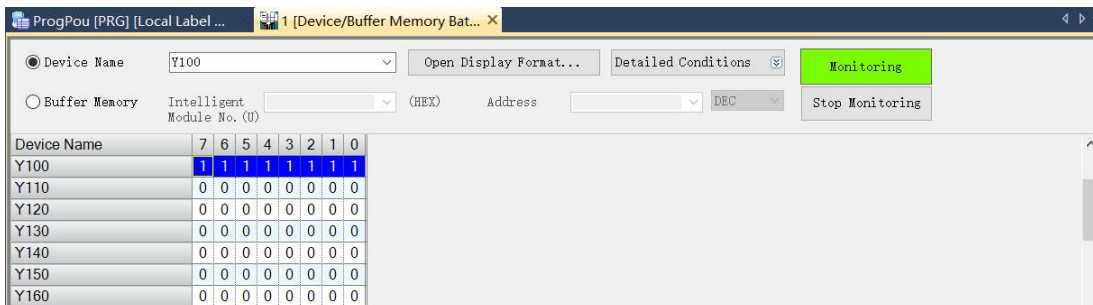

- iv. At this point, continue monitoring the X100 input mapping area, with channels 0-7 being labeled as "1".

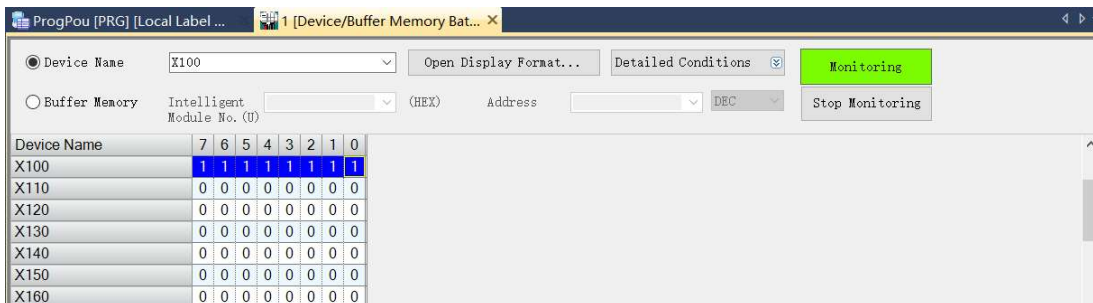

- v. Analog modules input and output testing.
 - a) Monitor the analog output data memory D404-D407 (D400-D403 are reserved registers), and input decimal values of 10000, 15000, 20000, and 25000 into each channel, as shown in the following figure:

Device Na	F	E	D	C	B	A	9	8	7	6	5	4	3	2	1	0	Current Value	String
D404	0	0	1	0	0	1	1	1	0	0	0	1	0	0	0	0	10000	!
D405	0	0	1	1	1	0	1	0	1	0	0	1	1	0	0	0	15000	?
D406	0	1	0	0	1	1	1	0	0	0	0	1	0	0	0	0	20000	N
D407	0	1	1	0	0	0	0	1	1	0	1	0	1	0	0	0	25000	=
D408	0	0	0	0	0	0	0	0	0	0	0	0	0	0	0	0	0	..
D409	0	0	0	0	0	0	0	0	0	0	0	0	0	0	0	0	0	..
D410	0	0	0	0	0	0	0	0	0	0	0	0	0	0	0	0	0	..
D411	0	0	0	0	0	0	0	0	0	0	0	0	0	0	0	0	0	..
D412	0	0	0	0	0	0	0	0	0	0	0	0	0	0	0	0	0	..
D413	0	0	0	0	0	0	0	0	0	0	0	0	0	0	0	0	0	..
D414	0	0	0	0	0	0	0	0	0	0	0	0	0	0	0	0	0	..
D415	0	0	0	0	0	0	0	0	0	0	0	0	0	0	0	0	0	..
D416	0	0	0	0	0	0	0	0	0	0	0	0	0	0	0	0	0	..
D417	0	0	0	0	0	0	0	0	0	0	0	0	0	0	0	0	0	..

b) Monitor the analog input data memory D204-D207 (D200 and D201 are module fault status registers, D202 and D203 are module connection status registers). The decimal values collected by each input channel are 9995, 14993, 19995, and 24970, respectively, which meet the design requirements of an acquisition error of less than 0.3%, as shown in the following figure:

Device Na	F	E	D	C	B	A	9	8	7	6	5	4	3	2	1	0	Current Value	String
D204	0	0	1	0	0	1	1	1	0	0	0	1	0	1	1	1	9995	!
D205	0	0	1	1	1	0	1	0	1	0	0	1	0	0	0	1	14993	?
D206	0	1	0	0	1	1	1	0	0	0	0	1	1	0	1	1	19995	.N
D207	0	1	1	0	0	0	0	1	1	0	0	1	0	0	1	1	24969	±
D208	0	0	0	0	0	0	0	0	0	0	0	0	0	0	0	0	0	..
D209	0	0	0	0	0	0	0	0	0	0	0	0	0	0	0	0	0	..
D210	0	0	0	0	0	0	0	0	0	0	0	0	0	0	0	0	0	..
D211	0	0	0	0	0	0	0	0	0	0	0	0	0	0	0	0	0	..
D212	0	0	0	0	0	0	0	0	0	0	0	0	0	0	0	0	0	..
D213	0	0	0	0	0	0	0	0	0	0	0	0	0	0	0	0	0	..
D214	0	0	0	0	0	0	0	0	0	0	0	0	0	0	0	0	0	..
D215	0	0	0	0	0	0	0	0	0	0	0	0	0	0	0	0	0	..
D216	0	0	0	0	0	0	0	0	0	0	0	0	0	0	0	0	0	..
D217	0	0	0	0	0	0	0	0	0	0	0	0	0	0	0	0	0	..

9.4. FX20 parameters configuration in web server

The FX20 CC-Link IE Field Basic adapter module supports web server functionality, which can be accessed by entering the IP address of the adapter module through a PC browser. This makes the configuration of FX20 I/O module parameters faster and more efficient.

9.4.1. Overview of FX20 web server parameter settings

Module Type	Parameters	Default value	Options
Digital input	Filter set	0ms	0ms,1ms,3ms,5ms,10ms
Digital output	Offline Status	Set to 0	Set to 0 Set to 1 Hold the last value
Analog input	Endian Set	Little endian	Little endian
			Big endian
	Range	Deactive	Deactive
			Current in +/-20 mA
			Current in 0...20 mA
			Current in 4...20 mA
			Voltage in +/-10 V
			Voltage in 0...10 V
	Filter set	Extremely weak	Voltage in 1...5 V
			Extremely weak
			weak
			medium
strong			
Extremely strong			
Diagnostic	Disable	Disable	
		Enable	
Analog output	Endian Set	Little endian	Little endian
			Big endian
	Range	Deactive	Deactive
			Current in +/-20 mA
			Current in 0...20 mA
			Current in 4...20 mA
			Voltage in +/-10 V
			Voltage in 0...10 V
	Filter set	Extremely weak	Voltage in 1...5 V
			Extremely weak
			weak
			medium
			strong
			Extremely strong
	Diagnostic	Disable	Disable
			Enable
			Set to 0

	Offline Status	Set to 0	Set to 1
	Substitute value	0	Hold the last value 0...65535

9.4.2. Instructions for using FX20 web server

9.4.2.1. Disconnect the FX20 from the PLC and connect it directly to the computer network port via Ethernet cable. Set the computer IP address to the same network segment as FX20, The FX20 default IP address is 192.168.3.10.

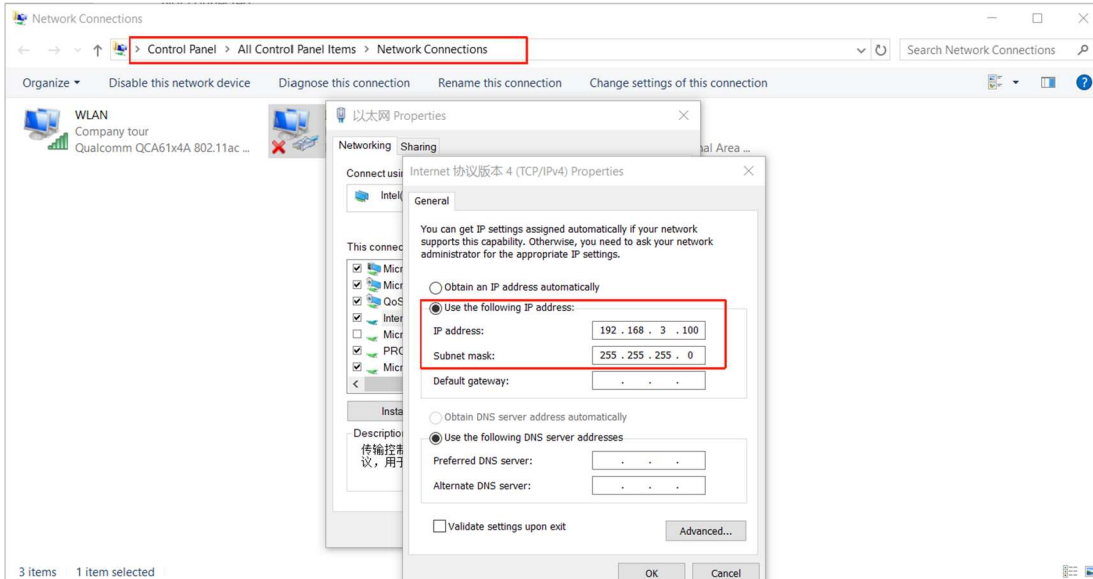

9.4.2.2. Open a computer browser, enter the IP address of the FX20 CC-Link IE Field Basic adapter in the address bar, press enter, and enter the FX20 web server homepage. On the homepage, you can view the product name, device ID, software version, MAC address, current IP address, and other information of the gateway module.



9.4.2.3. Click on "Home>Sub device" to view the I/O modules information connected to the gateway module.

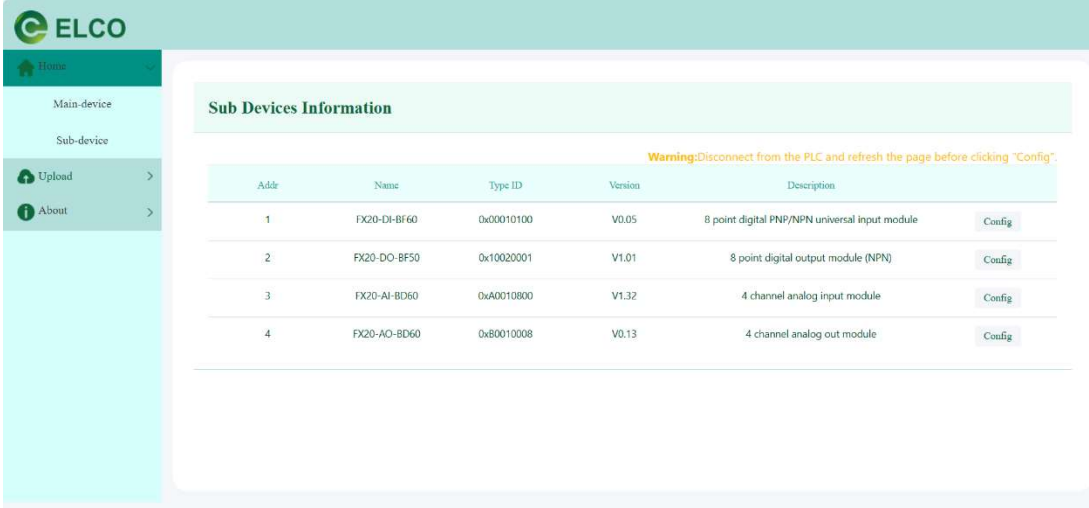

9.4.2.4. Digital input module configuration. Click on the "config" button corresponding to the digital input module to enter the corresponding configuration interface.

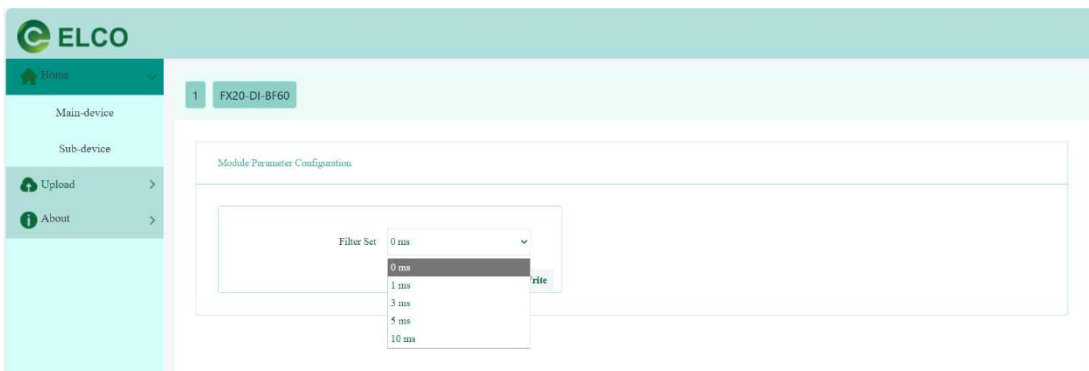

9.4.2.5. The configurable option for the digital input module is only the filtering time, which can be selected from five options: 0, 1, 3, 5, and 10ms. The longer the filtering time, the more effective the software will be in filtering out interference, and the corresponding input state acquisition period will also be extended. Please choose the appropriate filtering time as needed. Default is 0, turn off digital filtering. Click the write button to confirm the parameters, and click the read button to read the current parameters.



9.4.2.6. Digital output module configuration. Return to the "Sub Devices Information" page, select the "config" button corresponding to "FX20-DO-BF50", and enter the configuration page.

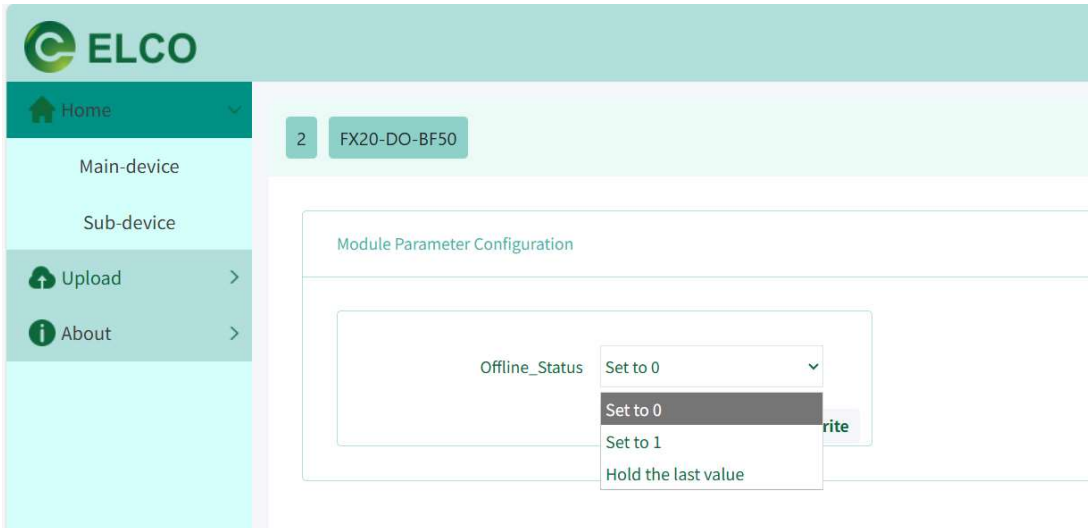

This page provides options for the output response of the digital output module when the bus network is interrupted, which is the output hold function.

Set to 0: After a bus network interruption, all output channels will be low level.

Set to 1: After the bus network is interrupted, all output channels will output high level.

Hold the last value: After a bus network interruption, all output channels will maintain their respective output states unchanged.

The default setting is "set to 0". After selecting, click the "write" button to write the parameters, and click the "read" button to view the current settings.

9.4.2.7. Analog input module configuration. Return to the “Sub Devices Information” page, select the "config" button corresponding to "FX20-AI-BD60", and enter the configuration page.

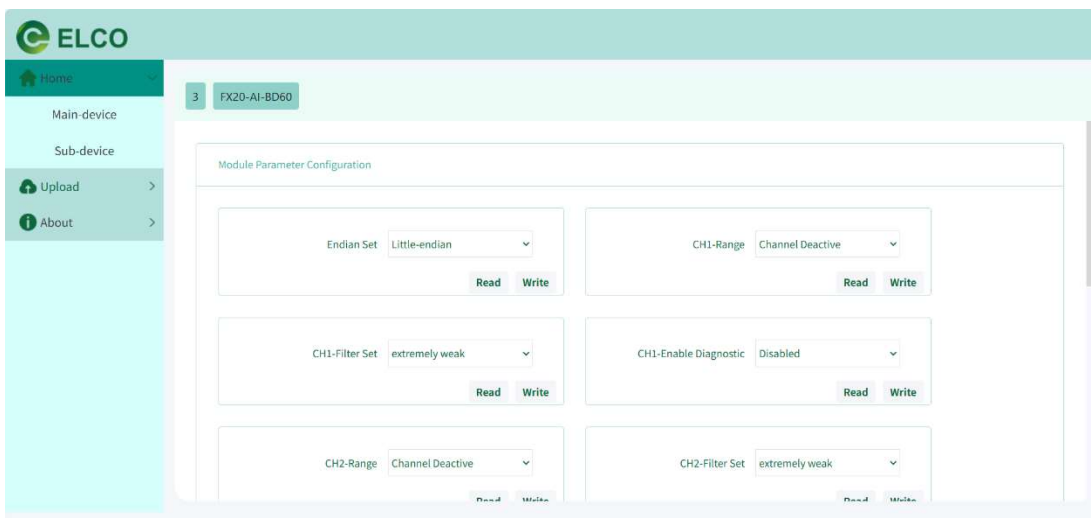

On this configuration page, the data bytes big or little endian of all channels in the module was configured, and configuration items were made for the signal range, filtering strength, and diagnostic enable of each of the four channels. We take channel 1 as an example to illustrate that the other channel settings are the same as channel 1.

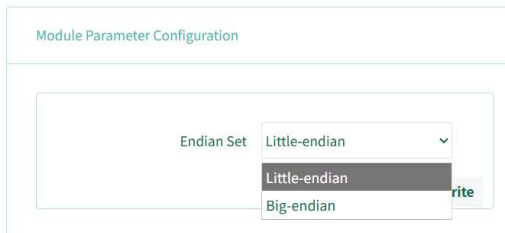

a) **Endian set:** Default Little endian, the correct byte storage format for analog data needs to be selected based on the PLC.

Little Endian: The low byte of the numerical value is stored in the low bit address of the memory, and the high byte is stored in the high bit address of the memory.

Big-endian: The high-order byte of the numerical value is stored in the low order address of the memory, and the low order byte is stored in the high-order address of the memory.

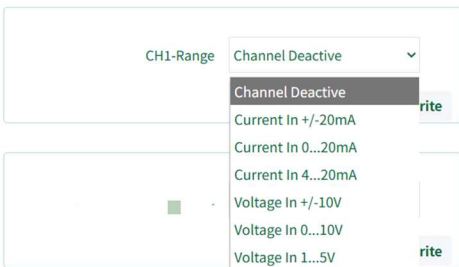

b) **CH1-Range:** Default channel deactive, Select the correct signal type and range based on the connected analog signal.

After selecting, click the "write" button to write the parameters, and click the "read" button to view the current settings.



c) **CH1-Filter Set:** The selection of filtering strength adopts software filtering method. Filtering enhancement will reduce interference signals, but it will also lower the sampling frequency, affecting the real-time performance of the signal. On the contrary, weakening the filtering will improve the real-time signal acquisition, but it will also introduce clutter interference. Please choose the appropriate software filtering strength according to the situation.

After selecting, click the "write" button to write the parameters, and click the "read" button to view the current settings.



d) CH1-Enable Diagnostic: Diagnosis enables control, when enable diagnostic is enabled, the diagnostic bytes of the gateway module will provide feedback on the alarm information of the channel. Please refer to 9.1.2 Register Allocation.

After selecting, click the "write" button to write the parameters, and click the "read" button to view the current settings.

9.4.2.8. Analog output module configuration. Return to the "Sub Devices Information" page, select the "config" button corresponding to "FX20-AO-BD60", and enter the configuration page.

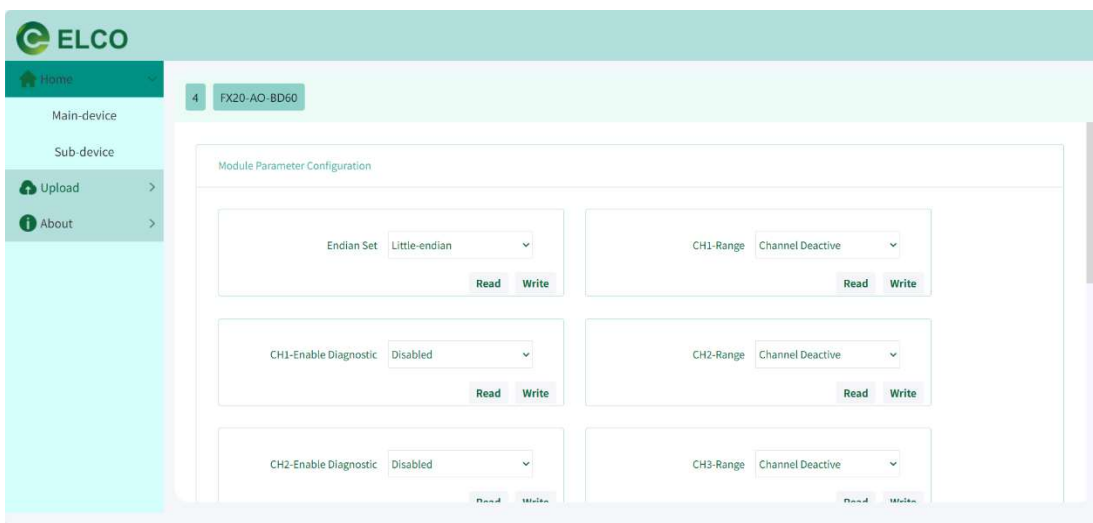

The three settings of Endian set, Range, and Enable Diagnostic are the same as those of the analog input module, as described in the previous section.

a) Analog output hold function setting

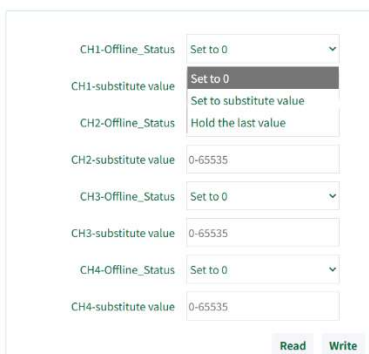

Set to 0: After a bus network interruption, all analog output channels of the module have output values of 0.

Set to substitute value: After the bus network is interrupted, the output channel of the module outputs a preset substitute value, with a range of decimal 0-65535.

Hold the last value: After a bus network interruption, all output channels will maintain their respective output states unchanged.

The default setting is "set to 0". After selecting, click the "write" button to write the parameters, and click the

"read" button to view the current settings.

9.4.2.9. Upload upgrade function

FX20 supports firmware upgrade operations through web servers. By importing upgrade files, firmware upgrades can be performed on FX20 couplers and I/O modules. Specific methods are attached separately.

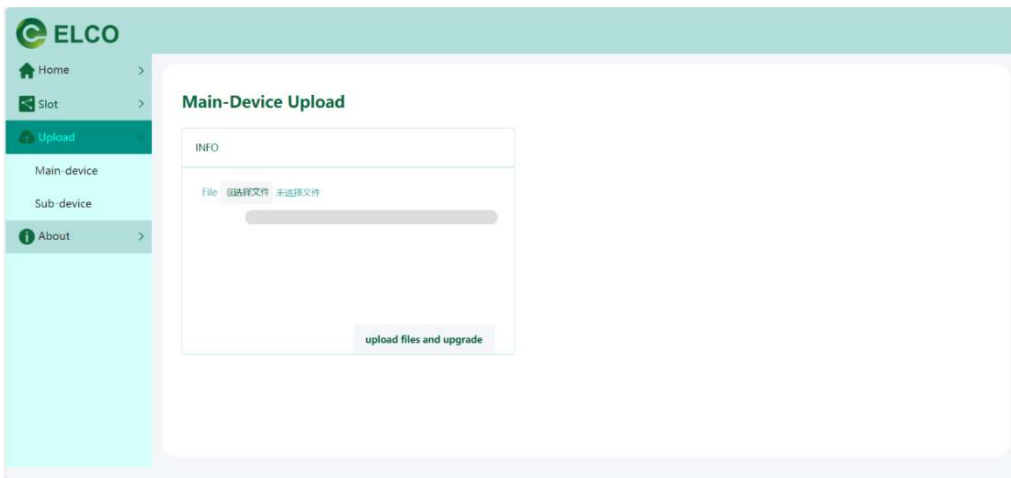

Caution!

1. Do not attempt to upgrade on your own unless necessary;
2. The upgrade file must be provided by the official ELCO company;
3. Do not power off during the upgrade process;
4. After the upgrade is completed, the FX20 power supply needs to be restarted.

9.5. Representation of analog module values

The PLC processes analog values in binary format. The FX20 analog input module converts analog process signals into digital format, and the analog output module converts digital output values into analog signals.

Digital analog values are applicable to input and output values within the same rated range. Each analog signal occupies PLC address of 1 word, which means each analog signal corresponds to a 16bit value. The symbol of the analog value is always set at the highest bit 15: 0 represents positive and 1 represents negative. For analog modules with a resolution less than 16 bits, analog values are stored in a left aligned manner, and the unused least significant bits are filled with 0. For example, the analog value 18035 can be represented as the following binary value:

Bits	15	14	13	12	11	10	9	8	7	6	5	4	3	2	1	0
16bit	0	1	0	0	0	1	1	0	0	1	1	1	0	0	1	1
14bit	0	1	0	0	0	1	1	0	0	1	1	1	0	0	0	0

Analog signal types can be divided into bipolar and unipolar, with a current bipolar value of $\pm 20\text{mA}$ (input only) and a voltage bipolar value of $\pm 10\text{V}$, the current unipolarity values are 0-20mA and 4-20mA, and the voltage unipolarity values are 1-5 V and 0-10 V.

The thermal resistor supports 2-wire and 3-wire PT100/1000, and the thermocouple can support multiple TC types (internal compensation) such as J, K, T, N, E, etc.

9.3.1. Analog value input and output range of bipolar current

System value		Current input/output range		
	Decimalism	Hexadecimal	$\pm 20\text{ mA}$	
118.515%	32767	7FFF	$\geq 23.7\text{ mA}$	Overflow, locking max. value
	27649	6C01		Overshoot range
100%	27648	6C00	20 mA	Rated range
75%	20736	5100	15 mA	
0.00362%	1	1	723.4 nA	
0%	0	0	0 mA	
	-1	FFFF	-723.4 nA	
-75%	-20736	AF00	-15 mA	
-100%	-27648	9400	-20 mA	
	-27649	93FF		Overshoot range
-118.519%	-32768	8000	$\leq -23.7\text{ mA}$	Underflow, locking min. value

9.3.2. Analog value input and output range of bipolar voltage

System value		Current input/output range		
	Decimalism	Hexadecimal	$\pm 10\text{V}$	
	32767	7FFF	$> 10.24\text{ V}$	Overflow, locking max. value
102.4%	28310	6E96	10.24 V	Overshoot range

	System value	Hexadecimal	Current input/output range	
	27649	6C01		
100%	27648	6C00	10 V	Rated range
75%	20736	5100	7.5 V	
0.00362%	1	1	361.7 μV	
0%	0	0	0 V	
	-1	FFFF	-361.7 μV	
-75%	-20736	AF00	-7.5 V	
-100%	-27648	9400	-10 V	
	-27649	93FF		Overshoot range
-102.4%	-28310	916A	-10.24 V	Underflow, locking min. value
	-32768	8000	< -10.24V	

9.3.3. Analog value input and output range of unipolar current

	System value		Current input/output range		
	Decimalism	Hexadecimal	0~20mA	4~20mA	
118.515%	32767	7FFF	≥ 23.7 mA	≥ 22.96 mA	Overflow, locking max. value
	27649	6C01			Overshoot range
100%	27648	6C00	20 mA	20 mA	Rated range
75%	20736	5100	15 mA	16 mA	
0.00362%	1	1	723.4 nA	4mA+578.7nA	
0%	0	0	0 mA	4 mA	
-0.00362%	-1	FFFF			Overshoot range
-17.59%	-4864	ED00	-3.52 mA	1.185 mA	
	-32768	8000	<-3.52 mA	< 1.185 mA	Underflow, locking min. value

9.3.4. Analog value input and output range of unipolar voltage

	System value		Current input/output range		
	Decimalism	Hexadecimal	1~5 V	0~10 V	
	32767	7FFF	> 5.7 V	> 10.24 V	Overflow, locking max. value
118.515%	32767	7FFF	5.7 V		Overshoot range
102.4%	28310	6E96		10.24 V	

100%	27648	6C00	5 V	10 V	Rated range
75%	20736	5100	4 V	7.5 V	
0.00362%	1	1	1V+144.7 μV	361.7 μV	
0%	0	0	1 V	0 V	
	-1	FFFF			Overshoot range
-17.59%	-4864	ED00		-1.759 V	
-25%	-6912	E500	0 V		
	-32768	8000	< 0 V	< -1.759 V	Underflow, locking min. value

9.3.5. Analog value measurement range of PT x00 standard thermal resistance

System value		Current input range	
Decimalism	Hexadecimal	-200~+850 °C	
32767	7FFF	≥ 850.1 °C	Overflow, locking max. value
8500	2134	850 °C	Rated range
6375	18E7	637.5 °C	
10	A	1 °C	
0	0	0 °C	
-10	FFF6	-1 °C	
-1500	FA24	-150 °C	
-2000	F830	-200 °C	
-32768	8000	≤ -200.1 °C	Underflow, locking min. value

9.3.6. Representation of simulated values within the measurement range of thermocouples

For J, K, T, N, and E type thermocouples, determine the rated input and output range based on the temperature range of the graduation table. Divide the decimalism value of the system by 10 to obtain the current temperature, with a resolution of 0.1 °C, and lock max. or min. value when exceeding the limit.

10. Fault diagnosis

Name	Status	Meaning	Recommended treatment
Adapter indicators			
PWR	Green	Normal	None
	Off	Power abnormal	<ol style="list-style-type: none"> 1. Check if the polarity of the power wiring is correct; 2. Check if the power supply voltage is normal; 3. Adapter failure, replace it.
BF	Green	Normal	None
	Red	Communication abnormal	<ol style="list-style-type: none"> 1. Check if the network cable is connected reliably; 2. Check for configuration errors; 3. Adapter failure, replace it.
SF	Green	Normal	None
	Red	Error occurred	<ol style="list-style-type: none"> 1. Check if there is a short circuit or overload in the I/O module; 2. Adapter or I/O module faulty, replace it;
STA	Green	Normal	None
	Red	Backplane communication error	<ol style="list-style-type: none"> 1. Check if the backplane connection between modules is reliable; 2. Attempt to power off and restart the FX20 system again;
Digital I/O indicators			
PW	Green	Normal	None
	Off	24V power supply abnormal	<ol style="list-style-type: none"> 1. Check if the 24V wiring of the I/O module is correct; 2. Check if the 24V power supply voltage of the I/O module is normal; 3. I/O module damaged, replace it.
MD	Green	Normal	None
	Green blinking	Connected but not configured	Check if the modules are configured correctly.
	Green and red blinking	Backplane communication abnormal	<ol style="list-style-type: none"> 1. Check if the connections between modules are reliable; 2. Restart FX20 system power supply; 3. I/O module malfunction, replace it.
	Red	Module error	<ol style="list-style-type: none"> 1. Check if the I/O module is configured correctly; 2. Check if there is a short circuit or overload in the I/O module; 3. I/O module damaged, replace it.
00-07/10-17	Green	Signal "1"	None
	Off	Signal "0"	None
Analog I/O indicators			
PW	Green	Normal	
	Off	24V power supply abnormal	<ol style="list-style-type: none"> 1. Check if the 24V wiring of the I/O module is correct; 2. Check if the 24V power supply voltage of the I/O module

			is normal; 3. I/O module damaged, replace.
MD	Green	Normal	None
	Green blinking	Connected but not configured	Check if the modules are configured correctly;
	Green and red blinking	Backplane communication abnormal;	1.Check if the connections between modules are reliable; 2. Restart FX20 system power supply; 3. I/O module malfunction, replace it.
	Red	Module error	1.Check if the I/O module is configured correctly; 2.Check if there is a short circuit or overload in the IO module; 3. The analog channel value exceeds the range; 4.I/O module damaged, replace.
C1-C4	Off	Normal	None
	Red	Channel over range	Check the analog input output signal range.
Auxiliary power supply module indicators			
PW	Green	Normal	None
	Red	24V overvoltage or undervoltage	Check if the input 24V power supply voltage is normal.
Us	Green	Normal	None
	Off	No backplane 5V power supply	1. Check if the backplane connection between modules is reliable; 2. Power module damaged, replace.